

STATE OF NORTH CAROLINA
DIVISION OF HIGHWAYS

BEAUFORT COUNTY

**LOCATION: BRIDGE #124 OVER JACK CREEK ON SR 1718
BETWEEN NC 92 AND SR 1722**

**TYPE OF WORK: REPLACE BRIDGE WITH BOX CULVERT,
PAVING, GRADING AND DRAINAGE**

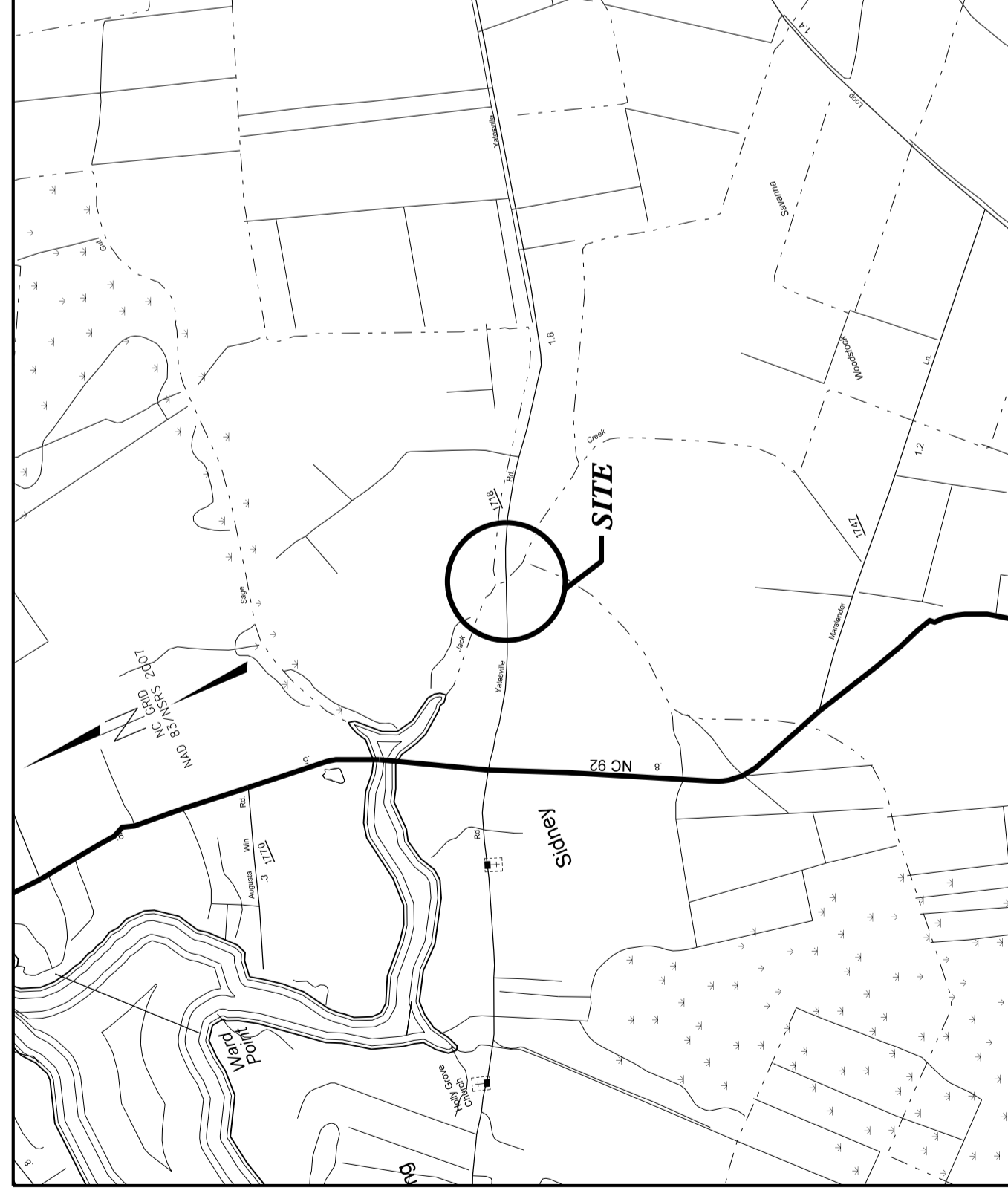

Vicinity Map
See Sheet 1-A For Index of Sheets

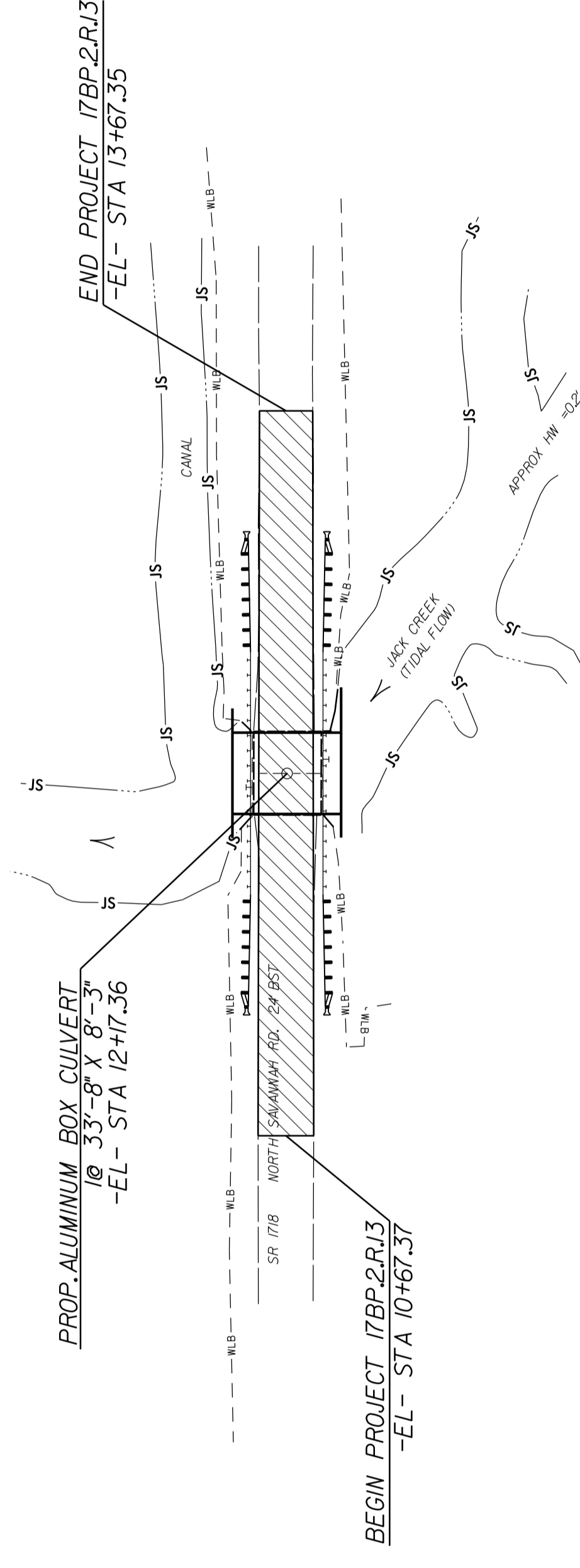
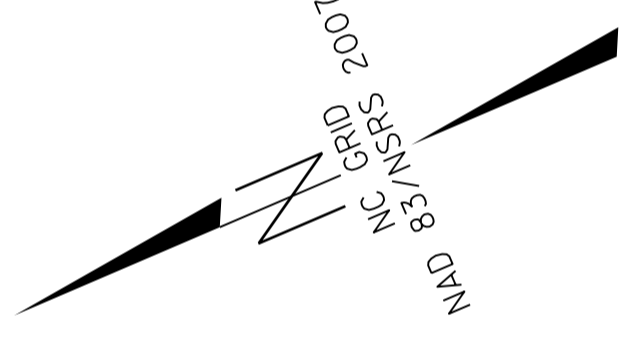

| | | | |
|-----------------|-----------------------------|-------------|--------------|
| STATE | STATE PROJECT REFERENCE NO. | SHEET NO. | TOTAL SHEETS |
| N.C. | 17BP.2.R.13 | 1 | |
| STATE PROJ. NO. | F.A. PROJ. NO. | DESCRIPTION | |
| | | | |
| | | | |
| | | | |
| | | | |

PROJECT: 17BP.2.R.13

CONTRACT:

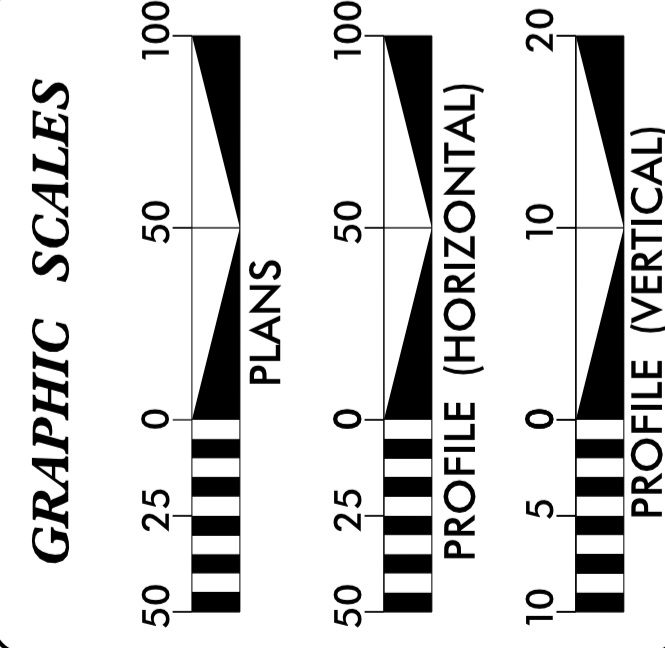

DESIGN DATA

PROJECT LENGTH

LENGTH ROADWAY PROJECT 17BP.2.R.13 = 0.051 MILES
LENGTH STRUCTURE PROJECT 17BP.2.R.13 = 0.006 MILES
TOTAL LENGTH PROJECT 17BP.2.R.13 = 0.057 MILES

Prepared in the Office of:

DIVISION OF HIGHWAYS
1704 N. GREENE ST. GREENVILLE, NC 27835

RIGHT OF WAY DATE:
N/A

LETTING DATE:
FEBRUARY 2013

| | |
|--|--|
| <p>HYDRAULICS ENGINEER</p> <p>PROFESSIONAL SEAL 16710</p> <p>DWAYNE H. ALLGOOD, P.E. SIGNATURE: <i>Dwayne H. Allgood</i> 02/07/2013</p> | <p>ROADWAY DESIGN ENGINEER</p> <p>PROFESSIONAL SEAL 16710</p> <p>DWAYNE H. ALLGOOD, P.E. SIGNATURE: <i>Dwayne H. Allgood</i> 02/07/2013</p> |
|--|--|

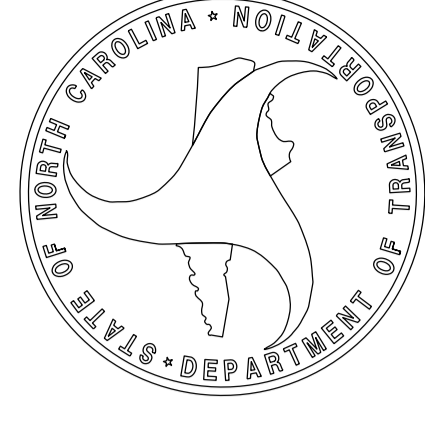

INDEX OF SHEETS

| SHEET NUMBER | SHEET |
|--------------|---|
| 1 | TITLE SHEET |
| 1A | INDEX OF SHEETS, GENERAL NOTES, STANDARD DRAWINGS |
| 1B | CONVENTIONAL SYMBOLS |
| 2 | TYPICAL SECTIONS |
| 3 | SUMMARY OF QUANTITIES |
| 3A | SUMMARY OF EARTHWORK, PAVEMENT REMOVAL, GUARDRAIL AND DRAINAGE QUANTITIES |
| 4 | PLAN AND PROFILE SHEET |
| UC1-UC4 | UTILITY CONSTRUCTION PLANS |
| TMPT-TMP2 | TRAFFIC MANAGEMENT PLANS |
| EC1-EC3 | EROSION CONTROL SHEETS |
| X1A | CROSS-SECTION SUMMARY |
| X1-X2 | CROSS-SECTIONS |

GENERAL NOTES:

2012 SPECIFICATIONS EFFECTIVE: 01/17/12
REVISED: 11/01/11

GRADING AND SURFACING OR RESURFACING AND WIDENING:

THE GRADE LINES SHOWN ABOVE THE FINISHED ELEVATION OF THE PROPOSED CURBS AND SIDEWALKS ARE TO BE CONSIDERED AS THE FINISHED GRADE LINES. ALL OTHER GRADE LINES SHOWN DENOTE THE TOP ELEVATION OF THE EXISTING PAVEMENT AND THE GRADE LINES MAY BE ADJUSTED BY THE ENGINEER IN ORDER TO SECURE A PROPER TIE-IN.

GRADING:

THE GRADE LINES SHOWN DENOTE THE FINISHED ELEVATION OF THE PROPOSED OR FUTURE SURFACING AT GRADE POINTS SHOWN ON THE TYPICAL SECTIONS. GRADE POINTS MAY BE ADJUSTED AT THEIR BEGINNING AND ENDING AND AT STRUCTURES AS DIRECTED BY THE ENGINEER IN ORDER TO SECURE A PROPER TIE-IN.

SUPERELEVATION:

ALL CURVES ON THIS PROJECT SHALL BE SUPERELEVATED IN ACCORDANCE WITH STD. NO. 225-04 USING THE RATE OF SUPERELEVATION AND RUNDFF SHOWN ON THE PLANS.

SHOULDER CONSTRUCTION:

ASPHALT, EARTH, AND CONCRETE SHOULDER CONSTRUCTION ON THE HIGH SIDE OF SUPERELEVATED CURVES SHALL BE IN ACCORDANCE WITH STD. NO. 560.01.

SIDE ROADS:

THE CONTRACTOR WILL BE REQUIRED TO DO ALL NECESSARY WORK TO PROVIDE EARTH AND CONCRETE SHOULDER CONSTRUCTION ON THE LOW SIDE OF SUPERELEVATED CURVES. THIS WORK WILL BE PAID FOR AT THE CONTRACT UNIT PRICE FOR THE PARTICULAR ITEMS INVOLVED.

UTILITIES:

ALL EXISTING UTILITIES SHOWN ON PLANS ARE APPROXIMATE.

UTILITY OWNERS ON THIS PROJECT ARE AS FOLLOWS:
BEAUFORT WATER DEPT. (WATER) CONTACT: EFFIE WENNING, 252-402-6547
BEAUFORT TELEPHONE CO. (TELEPHONE) CONTACT: MICHAEL WATSON, 252-964-6000
TIDELAND EMC (POWER) CONTACT: MICHAEL MARSLANDER, 252-943-3046

RIGHT-OF-WAY MARKERS:
ALL RIGHT-OF-WAY MARKERS ON THIS PROJECT SHALL BE PLACED BY OTHERS.

2012 ROADWAY ENGLISH STANDARD DRAWINGS

The following Roadway Standards as appear in "Roadway Standard Drawings" Highway Design Branch - and by reference hereby are considered a part of these plans:

200-02 Method of Clearing - Method 11
225-02 Guide for Grading, Subgrade and Loam
252-02 Method of Grading Super-elevation - Two Lane Pavement
300-01 PIPE CULVERTS
300-01 Method of Pipe Installation - Method 'A'

DIVISION 8 - INCIDENTALS
876.02 Guide for Rip Rap at Pipe Outlets

Note: Not to Scale

*S.U.E. = Subsurface Utility Engineering











STATE OF NORTH CAROLINA
DIVISION OF HIGHWAYS

PROJECT REFERENCE NO.
17BP2RJ3













SHEET NO.
1B

CONVENTIONAL PLAN SHEET SYMBOLS











BOUNDARIES AND PROPERTY:

- State Line _____
- County Line _____
- Township Line _____
- City Line _____
- Reservation Line _____
- Property Line _____
- Existing Iron Pin  _____
- Property Corner _____
- Property Monument  _____
- Parcel/Sequence Number  _____
- Existing Fence Line  _____
- Proposed Woven Wire Fence  _____
- Proposed Chain Link Fence  _____
- Proposed Barbed Wire Fence  _____
- Existing Wetland Boundary  _____
- Proposed Wetland Boundary  _____
- Existing Endangered Animal Boundary  _____
- Existing Endangered Plant Boundary  _____





BUILDINGS AND OTHER CULTURE:

- Gas Pump  _____
- Vent or UG Tank Cap  _____
- Sign  _____
- Well  _____
- Small Mine  _____
- Foundation  _____
- Area Outline  _____
- Cemetery  _____
- Building  _____
- School  _____
- Church  _____
- Dam  _____















HYDROLOGY:

- Stream or Body of Water _____
- Hydro, Pool or Reservoir  _____
- Jurisdictional Stream  _____
- Buffer Zone 1  _____
- Buffer Zone 2  _____
- Flow Arrow  _____
- Disappearing Stream  _____
- Spring  _____
- Wetland  _____
- Proposed Lateral, Tail, Head Ditch  _____
- False Sump  _____

















RAILROADS:

- Standard Gauge  _____
- RR Signal Milepost  _____
- Switch  _____
- RR Abandoned  _____
- RR Dismantled  _____









RIGHT OF WAY:

- Baseline Control Point  _____
- Existing Right of Way Marker  _____
- Existing Right of Way Line  _____
- Proposed Right of Way Line  _____
- Proposed Right of Way Line with Iron Pin and Cap Marker  _____
- Proposed Right of Way Line with Concrete or Granite Marker  _____
- Existing Control of Access  _____
- Proposed Control of Access  _____
- Existing Easement Line  _____
- Proposed Temporary Construction Easement  _____
- Proposed Temporary Drainage Easement  _____
- Proposed Permanent Drainage Easement  _____
- Proposed Permanent Utility Easement  _____
- Proposed Temporary Utility Easement  _____
- Proposed Permanent Easement with Iron Pin and Cap Marker  _____











ROADS AND RELATED FEATURES:

- Existing Edge of Pavement  _____
 - Existing Curb  _____
 - Proposed Slope Stakes Cut  _____
 - Proposed Slope Stakes Fill  _____
 - Proposed Wheel Chair Ramp  _____
 - Existing Metal Guardrail  _____
 - Proposed Guardrail  _____
 - Existing Cable Guiderail  _____
 - Proposed Cable Guiderail  _____
 - Equality Symbol  _____
 - Pavement Removal  _____
- ### VEGETATION:
- Single Tree  _____
 - Single Shrub  _____
 - Hedge  _____
 - Woods Line  _____
 - Orchard  _____
 - Vineyard  _____













EXISTING STRUCTURES:

- MAJOR:
 - Bridge, Tunnel or Box Culvert  _____
 - Bridge Wing Wall, Head Wall and End Wall  _____
- MINOR:
 - Head and End Wall  _____
 - Pipe Culvert  _____
 - Footbridge  _____
 - Drainage Box: Catch Basin, DI or JB  _____
 - Paved Ditch Gutter  _____
 - Storm Sewer Manhole  _____
 - Storm Sewer  _____







UTILITIES:

- POWER:
 - Existing Power Pole  _____
 - Proposed Power Pole  _____
 - Existing Joint Use Pole  _____
 - Proposed Joint Use Pole  _____
 - Power Manhole  _____
 - Power Line Tower  _____
 - Power Transformer  _____
 - UG Power Cable Hand Hole  _____
 - H-Frame Pole  _____
 - Recorded UG Power Line  _____
 - Designated UG Power Line (S.U.E.*)  _____









TELEPHONE:

- Existing Telephone Pole  _____
- Proposed Telephone Pole  _____
- Telephone Manhole  _____
- Telephone Booth  _____
- Telephone Pedestal  _____
- Telephone Cell Tower  _____
- UG Telephone Cable Hand Hole  _____
- Recorded UG Telephone Cable  _____
- Designated UG Telephone Cable (S.U.E.*)  _____
- Recorded UG Telephone Conduit  _____
- Designated UG Telephone Conduit (S.U.E.*)  _____
- Recorded UG Fiber Optics Cable  _____
- Designated UG Fiber Optics Cable (S.U.E.*)  _____





WATER:

- Water Manhole  _____
- Water Meter  _____
- Water Valve  _____
- Water Hydrant  _____
- Recorded UG Water Line  _____
- Designated UG Water Line (S.U.E.*)  _____
- Above Ground Water Line  _____







TV:

- TV Satellite Dish  _____
- TV Pedestal  _____
- TV Tower  _____
- UG TV Cable Hand Hole  _____
- Recorded UG TV Cable  _____
- Designated UG TV Cable (S.U.E.*)  _____
- Recorded UG Fiber Optic Cable  _____
- Designated UG Fiber Optic Cable (S.U.E.*)  _____











GAS:

- Gas Valve  _____
- Gas Meter  _____
- Recorded UG Gas Line  _____
- Designated UG Gas Line (S.U.E.*)  _____
- Above Ground Gas Line  _____

SANITARY SEWER:

- Sanitary Sewer Manhole  _____
- Sanitary Sewer Cleanout  _____
- UG Sanitary Sewer Line  _____
- Above Ground Sanitary Sewer  _____
- Recorded SS Forced Main Line  _____
- Designated SS Forced Main Line (S.U.E.*)  _____

MISCELLANEOUS:

- Utility Pole  _____
- Utility Pole with Base  _____
- Utility Located Object  _____
- Utility Traffic Signal Box  _____
- Utility Unknown UG Line  _____
- UG Tank; Water, Gas, Oil  _____
- AG Tank; Water, Gas, Oil  _____
- UG Test Hole (S.U.E.*)  _____
- Abandoned According to Utility Records  _____
- End of Information  _____

| | |
|----|--|
| C1 | PROP. APPROX. 1 1/2" ASPHALT CONCRETE SURFACE COURSE, TYPE S9.5B, AT AN AVERAGE RATE OF 168 LBS. PER SQ. YD. |
| D1 | PROP. APPROX. 3" ASPHALT CONCRETE INTERMEDIATE COURSE, TYPE I19.0B, AT AN AVERAGE RATE OF 342 LBS. PER SQ. YD. |
| D2 | PROP. VARIABLE DEPTH WEDGING ASPHALT CONCRETE INTERMEDIATE COURSE, TYPE I19.0B. |
| E1 | PROP. APPROX. 5" ASPHALT CONCRETE BASE COURSE, TYPE B25.0B, AT AN AVERAGE RATE OF 570 LBS. PER SQ. YD. |
| J | APPROX. 12" AGGREGATE BASE COURSE |
| T | EARTH MATERIAL. |
| U | EXISTING PAVEMENT. |
| V | FILTER FABRIC |
| Y | #57 WASHED STONE |

NOTE: PAVEMENT EDGE SLOPES ARE 1:1 UNLESS SHOWN OTHERWISE.

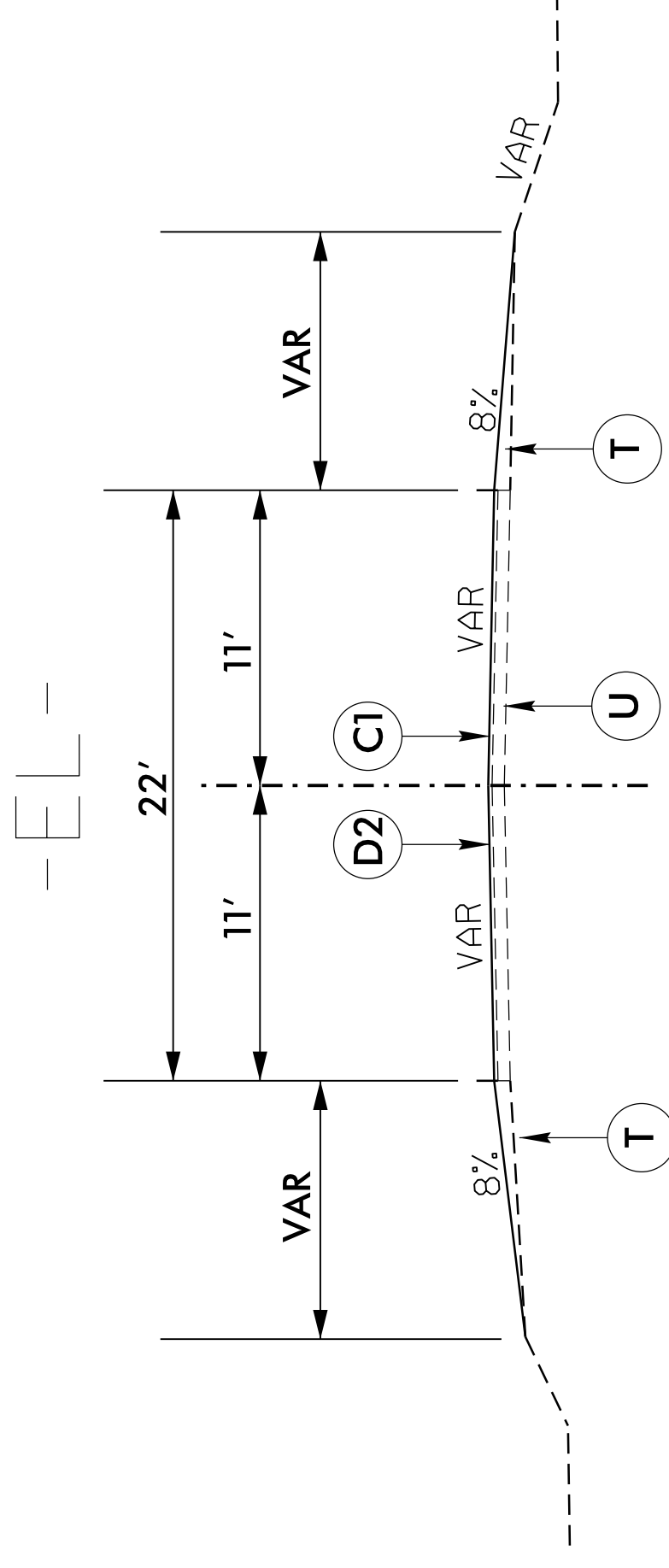

TYPICAL SECTION #1

TRANSITION FROM TYPICAL SECTION #1 TO TYPICAL SECTION #2
 -EL- STATION 10+67.37 - 11+17.37
 -EL- STATION 13+17.35 - 13+67.35

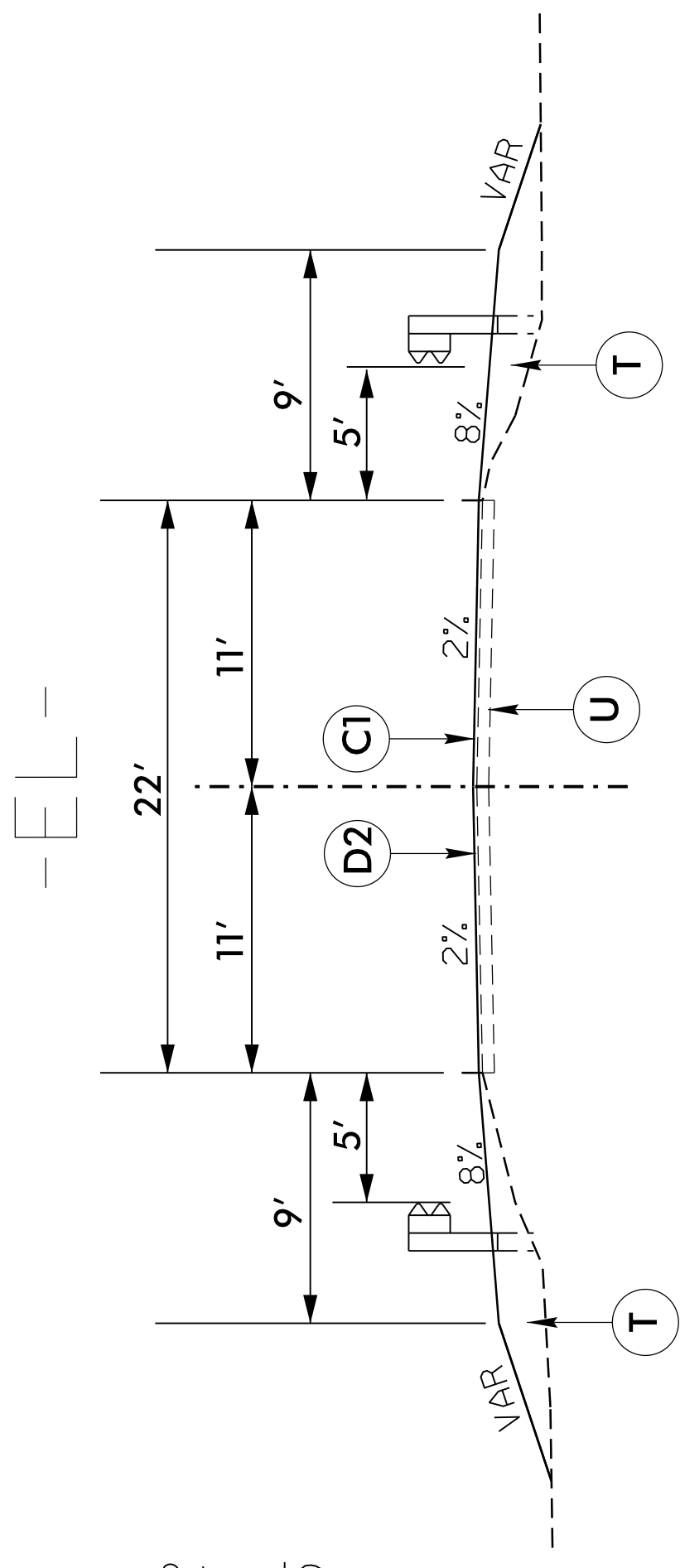

TYPICAL SECTION #2

-EL- STATION 11+17.37 - 11+73.85
 -EL- STATION 12+60.42 - 13+17.35

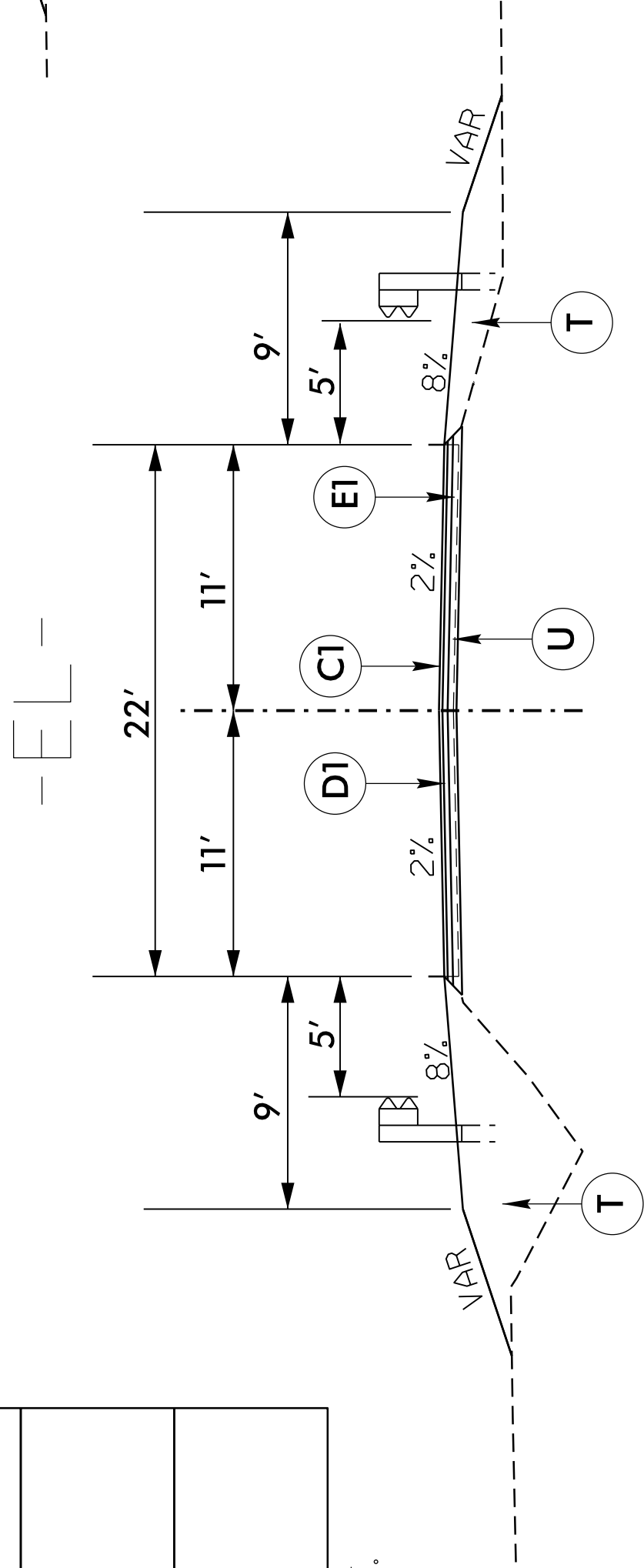

TYPICAL SECTION #3

-EL- STATION 11+73.85 - 12+60.42

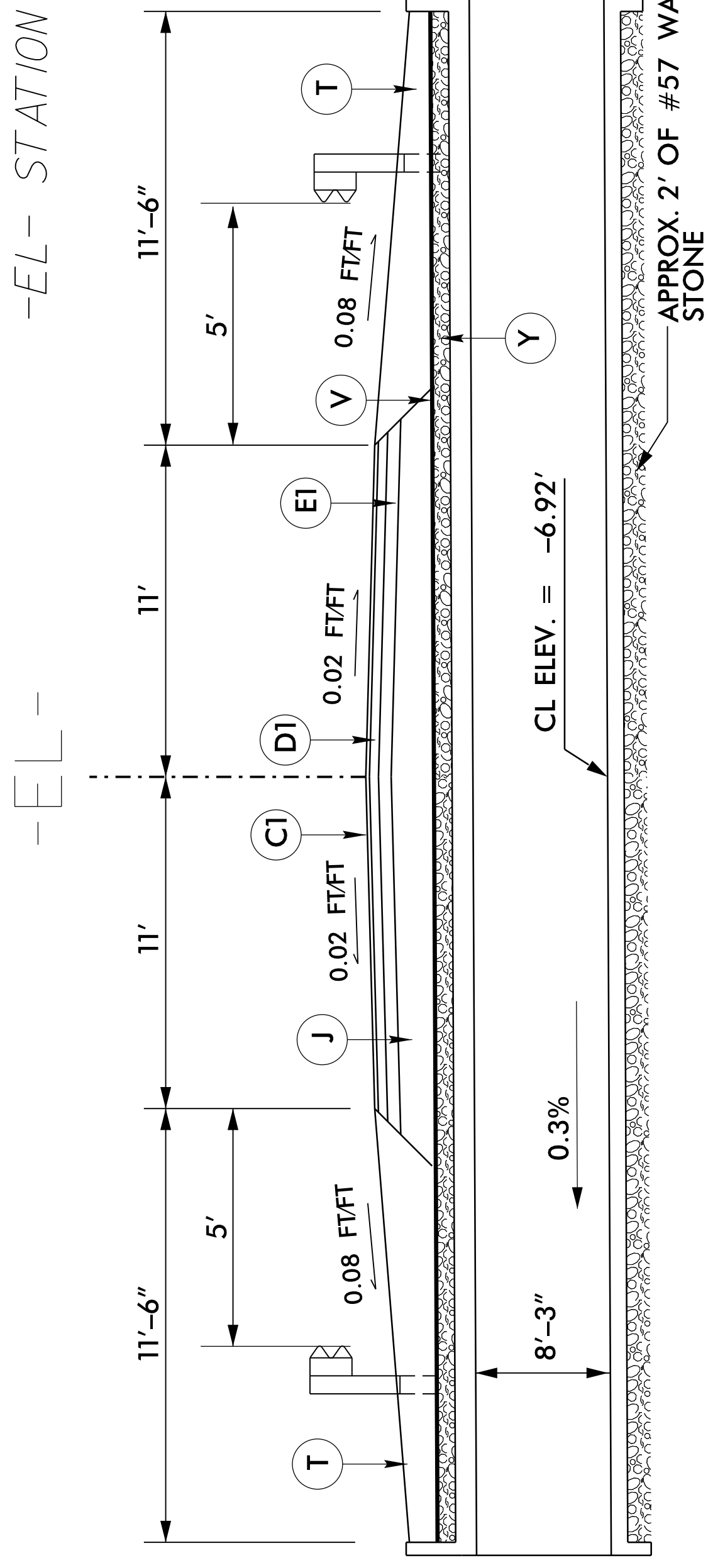

TYPICAL BOX CULVERT SECTION #4 (NTS)

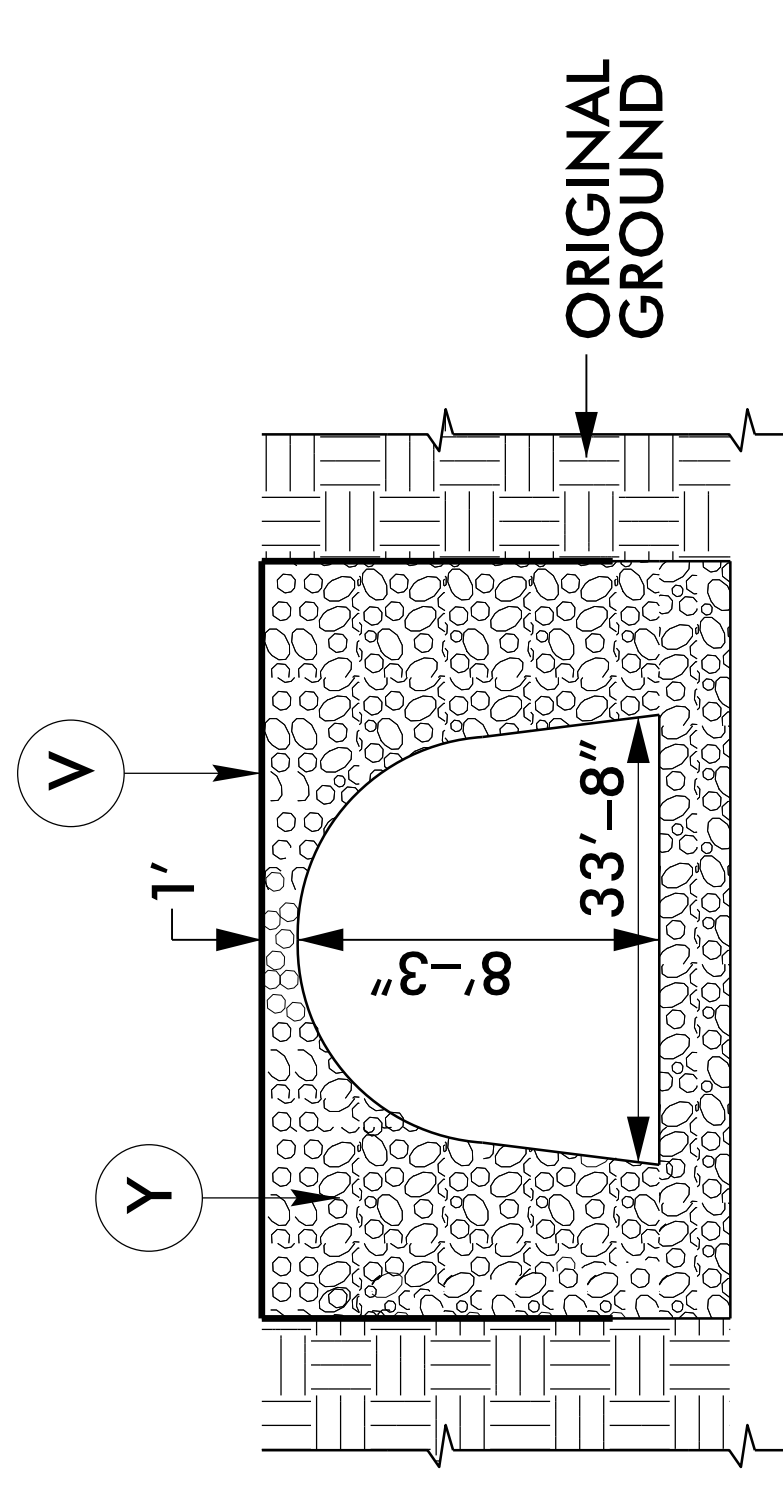

END VIEW BOX CULVERT (NTS)

STATE OF NORTH CAROLINA
 DIVISION OF HIGHWAYS
 SUMMARY OF QUANTITIES

| SECT | QUANTITY | UNIT | ITEM DESCRIPTION |
|------|----------|------|--|
| 800 | 1 | LS | MOBILIZATION |
| 801 | 1 | LS | CONSTRUCTION SURVEYING |
| SP | 1 | LS | GRADING |
| SP | 100 | CY | UNDERCUT EXCAVATION |
| 520 | 65 | TON | AGGREGATE BASE COURSE |
| 610 | 80 | TON | ASPHALT CONCRETE BASE COURSE,TYPE B25.0B |
| 610 | 45 | TON | ASPHALT CONCRETE INTERMEDIATE COURSE,TYPE I19.0B |
| 610 | 80 | TON | ASPHALT CONCRETE SURFACE COURSE,TYPE S9.5B |
| 620 | 15 | TON | ASPHALT BINDER FOR PLANT MIX,GRADE P664-22 |
| 862 | 200 | LF | STEEL BEAM GUARDRAIL |
| SP | 4 | EA | GUARDRAIL ANCHOR UNITS,TYPE 350 |
| 876 | 250 | SY | GEOTEXTILE FOR DRAINAGE |
| 1605 | 650 | LF | TEMPORARY SILT FENCE |
| 1610 | 10 | TON | STONE FOR EROSION CONTROL,CLASS B |
| 1610 | 10 | TON | SEDIMENT CONTROL STONE |
| 1615 | 0.5 | ACRE | TEMPORARY MULCHING |
| 1620 | 20 | LB | SEED FOR TEMPORARY SEEDING |
| 1620 | 01 | TON | FERTILIZER FOR TEMPORARY SEEDING |
| 1630 | 30 | CY | SILT EXCAVATION |
| 1631 | 1000 | SY | MATTING FOR EROSION CONTROL |
| 1632 | 100 | LF | 1/4" HARDWARE CLOTH |
| SP | 100 | LF | WATTLE |
| 1660 | 1 | ACRE | SEEDING AND MULCHING |
| 1661 | 50 | LB | SEED FOR REPAIR SEEDING |
| 1661 | 0.2 | TON | FERTILIZER FOR REPAIR SEEDING |
| SP | 150 | SY | TURBIDITY CURTAIN |
| SP | 3 | EA | RESPONSE FOR EROSION CONTROL |
| 402 | 1 | LS | REMOVAL OF EXISTING STRUCTURE AT -EL- STATION 12+17.36 |
| SP | 1 | LS | 1 @ 8'-3" X 33'-8" CORRUGATED ALUMINUM BOX CULVERT WITH HEADWALLS AT -EL- STATION 12+17.36 |
| SP | 1 | LS | RELOCATE EXISTING 6" WATER MAIN |

REVISIONS

STATE OF NORTH CAROLINA
 DIVISION OF HIGHWAYS

LIST OF PIPES, ENDWALLS, ETC.

| STATION | LOCATION (LT, RT, OR CL) | STRUCTURE NO. | TOP ELEVATION | INVERT ELEVATION | INVERT ELEVATION | SLOPE CRITICAL | DRAINAGE PIPE (RCP, CSP, CAP, HDPE or PVC) | | | | | ALUMINUM BOX CULVERT |
|-----------------|--------------------------|---------------|---------------|------------------|------------------|----------------|--|-------------|-------------|----------------|----------------|------------------------|
| | | | | | | | 12" 15' | 18" 24" 30" | 36" 42" 48" | DO NOT USE RCP | DO NOT USE CSP | |
| -EL- 12 + 17.36 | CL | 1 | -6.85 | -6.99 | 0.5% | | | | | | | 1 @ 33'-8" X 8'-3" ABC |
| TOTALS | | | | | | | | | | | | |
| | | | | | | | | | | | | 1 |

NOTE: Invert Elevations are for Bid Purposes only and shall not be used for project construction stakeout. See "Standard Specifications For Roads and Structures, Section 300-5".

**SUMMARY OF EARTHWORK
 IN CUBIC YARDS**

| LOCATION | UNCLASSIFIED EXCAVATION | STRUCTURE EXCAVATION | UNDERCUT | EMBT + % | BORROW | WASTE |
|------------------------------|-------------------------|----------------------|----------|----------|--------|-------|
| -EL- 10 + 67.37 - 13 + 67.35 | 54 | 1,175 | 0 | 473 | 473 | 1,175 |
| UNDERCUT (CONTINGENCY) | 0 | 0 | 100 | 120 | 120 | 100 |
| SUB TOTAL | 54 | 1,175 | 100 | 593 | 593 | 1,275 |
| SAY | 60 | 1,200 | 100 | 600 | 600 | 1,300 |

**PAVEMENT REMOVAL SUMMARY
 IN SQUARE YARDS**

| LINE | STATION - STATION | LOCATION | REMOVAL (SY) |
|-------|-------------------------|----------|--------------|
| -EL- | 11 + 73.85 - 12 + 60.42 | CL | 140 |
| TOTAL | | | 140 |
| SAY | | | 150 |

NOTE:

APPROXIMATE QUANTITIES ONLY. UNCLASSIFIED EXCAVATION, UNCLASSIFIED STRUCTURE EXCAVATION, BORROW EXCAVATION, FINE GRADING, CLEARING AND GRUBBING AND REMOVAL OF EXISTING PAVEMENT WILL BE PAID FOR AT THE CONTRACT LUMP SUM PRICE FOR "GRADING."

"N" = DISTANCE FROM EDGE OF LANE TO FACE OF GUARDRAIL
 TOTAL SHOULDER WIDTH = DISTANCE FROM EDGE OF TRAVEL LANE TO SHOULDER BREAK POINT.
 FLARE LENGTH = DISTANCE FROM LAST SECTION OF PARALLEL GUARDRAIL TO END OF GUARDRAIL.
 W = TOTAL WIDTH OF FLARE FROM BEGINNING OF TAPER TO END OF GUARDRAIL.
 G = GATING IMPACT ATTENUATOR TYPE 350
 NG = NON-GATING IMPACT ATTENUATOR TYPE 350

GUARDRAIL SUMMARY

| SURVEY LINE | BEG. STA. | END STA. | LOCATION | LENGTH | | WARRANT POINT | | TOTAL SHOULDER WIDTH | FLARE LENGTH | | | ANCHORS | | | REMARKS | |
|-------------|------------|------------|----------|----------|-------------|---------------|--------------|----------------------|--------------|--------------|----------|----------------------------|-----------|-----|---------|---|
| | | | | STRAIGHT | SHOP CURVED | APPROACH END | TRAILING END | | APPROACH END | TRAILING END | TYPE 350 | IMPACT ATTENUATOR TYPE 350 | PERMITTED | NO. | | G |
| -EL- | 11 + 17.37 | 13 + 17.37 | LT | 100 | | 13 + 17.37 | | 9 | 50 | 50 | 1 | 1 | 2 | | | |
| -EL- | 11 + 17.37 | 13 + 17.37 | RT | 100 | | 11 + 17.37 | | 9 | 50 | 50 | 1 | 1 | 2 | | | |
| TOTAL | | | | 200 | | | | | | | | | 4 | | | |

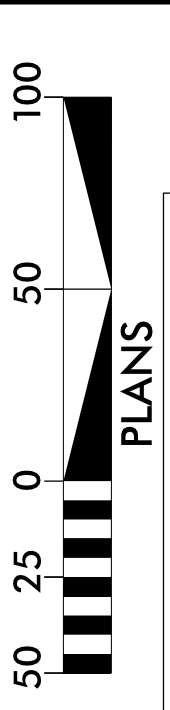

NAD 83 NSRS 2007

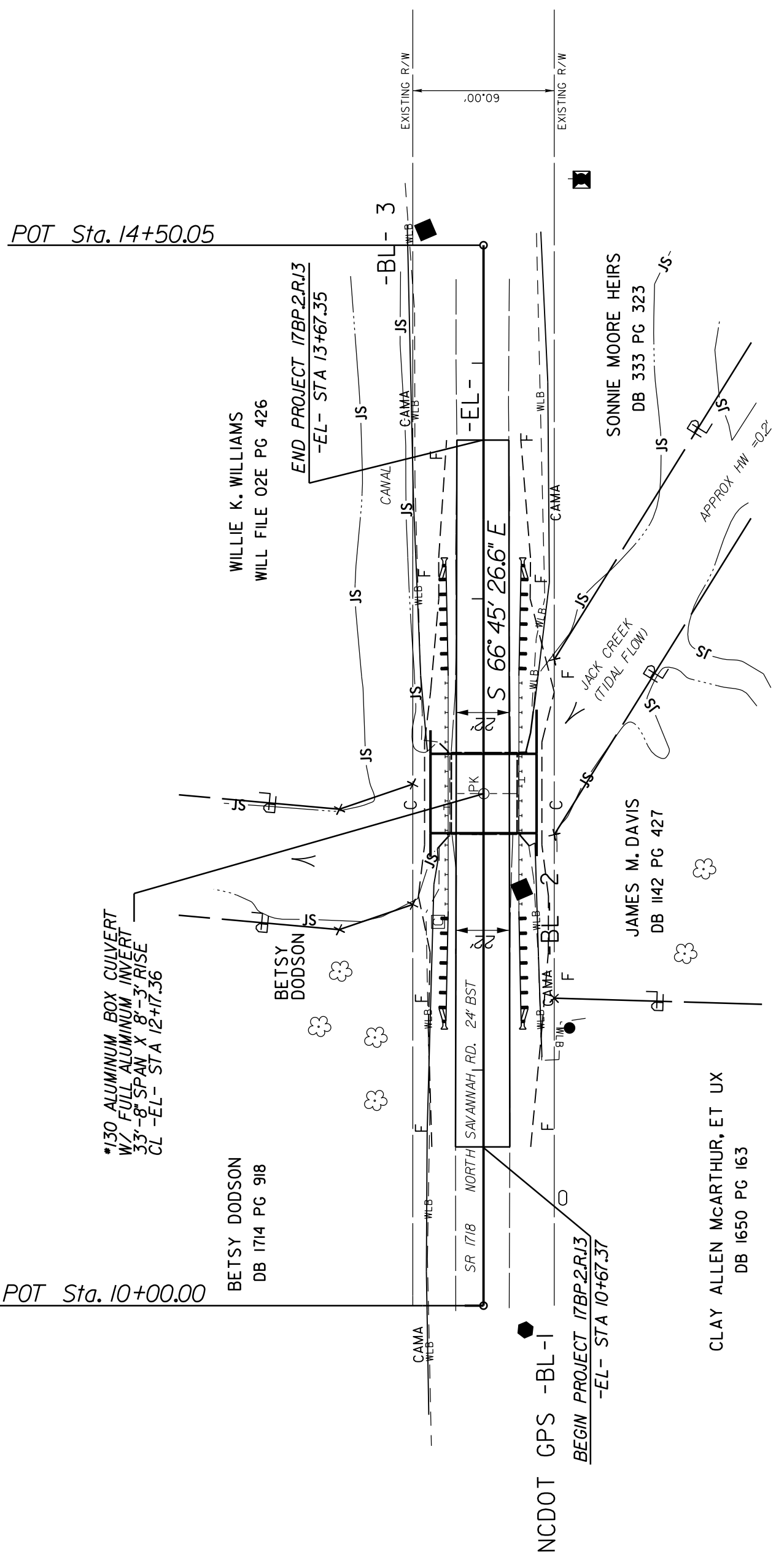

| Point | North | East | Elevation | Description |
|-------|-------------|--------------|-----------|--------------------|
| BL1 | 637043.2280 | 2693804.8370 | 2.7320 | NCDOT GPS BL-1 |
| BL2 | 636970.8698 | 2693977.1979 | 2.8600 | BL-2 |
| BL3 | 636897.9527 | 2694250.4511 | 2.1200 | BL-3 |
| BMI | 636828.6987 | 2694243.9158 | 3.8700 | RR SPIKE SET IN PP |

DATUM DESCRIPTION
 THE LOCALIZED COORDINATE SYSTEM DEVELOPED FOR THIS PROJECT IS BASED ON THE STATE PLANE COORDINATES ESTABLISHED BY NCDOT FOR MONUMENT "BL1"
 WITH NAD 83/NSRS 2007 STATE PLANE GRID COORDINATES OF NORTHING: 637043.228(FT) EASTING: 2693804.837(FT)
 ELEVATION: 2.732(FT)
 THE AVERAGE COMBINED GRID FACTOR USED ON THIS PROJECT (GROUND TO GRID) IS: 0.99886050
 THE N.C. LAMBERT GRID BEARING AND LOCALIZED HORIZONTAL GROUND DISTANCE FROM "BL1" TO -EL- STATION 10+00.00 IS N 53°13'35.6"E 20.51'
 ALL LINEAR DIMENSIONS ARE LOCALIZED HORIZONTAL DISTANCES VERTICAL DATUM USED IS NAVD 88

-L- PROFILE
 SCALE: 1"=50' HORIZ.
 1"=10' VERT.

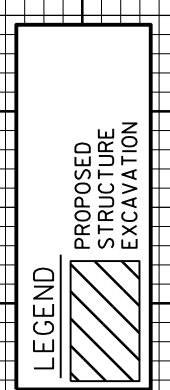

BEGIN GRADE
 -EL- STA 10+67.37
 ELEV.= 4.47

END GRADE
 -EL- STA 13+67.37
 ELEV.= 3.50

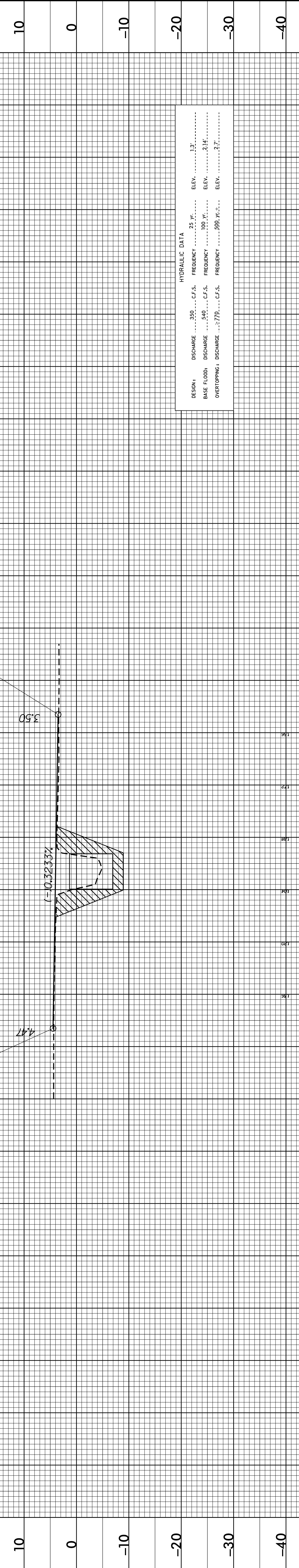

HYDRAULIC DATA

| DESIGN: | DISCHARGE | 350 | CF.S. | FREQUENCY | 25 | Yr. | ELEV. | 1.3 |
|--------------|-----------|-----|-------|-----------|-----|-----|-------|------|
| BASE FLOOD: | DISCHARGE | 540 | CF.S. | FREQUENCY | 100 | Yr. | ELEV. | 2.14 |
| OVERTOPPING: | DISCHARGE | 779 | CF.S. | FREQUENCY | 500 | Yr. | ELEV. | 2.7 |

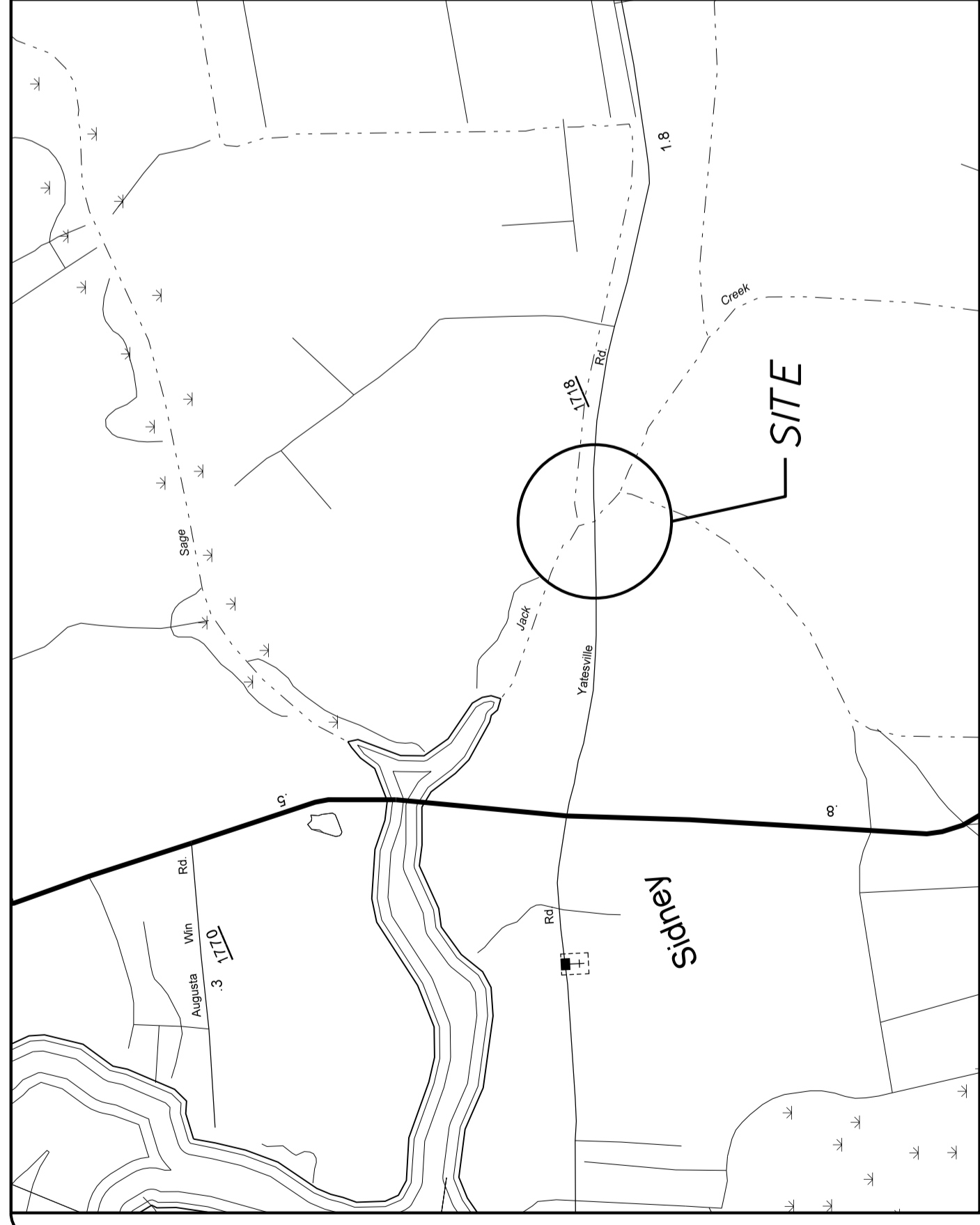

Vicinity Map

TIP PROJECT: 17.BP.2.R.13

CONTRACT:

STATE OF NORTH CAROLINA
DIVISION OF HIGHWAYS

BEAUFORT COUNTY

**LOCATION: BRIDGE #124 OVER JACK CREEK ON SR 1718
BETWEEN NC 92 AND SR 1722**

**TYPE OF WORK: UTILITY CONSTRUCTION
WATER MAIN RELOCATION**

| | | | |
|-----------------|-----------------------------|-------------|--------------|
| STATE | STATE PROJECT REFERENCE NO. | SHEET NO. | TOTAL SHEETS |
| N.C. | 17BP.2.R.13 | U1 | 4 |
| STATE PROJ. NO. | F.A. PROJ. NO. | DESCRIPTION | |
| | | | |
| | | | |
| | | | |
| | | | |
| | | | |

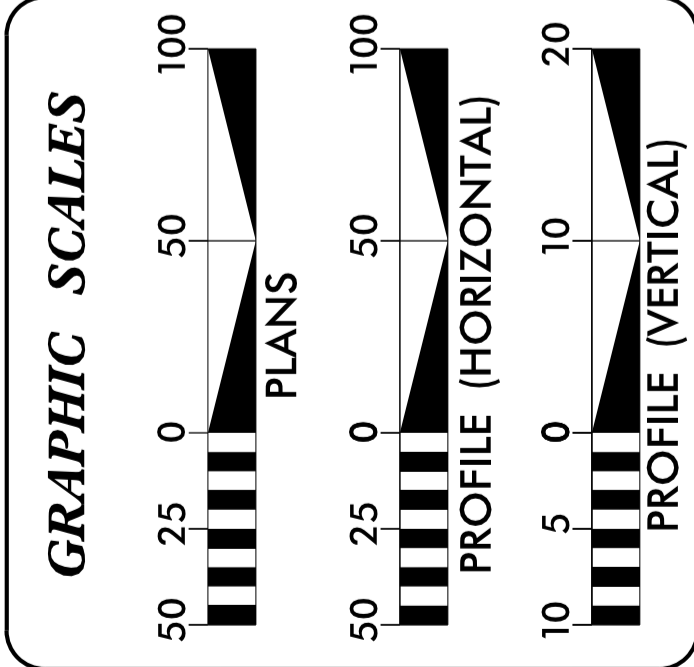
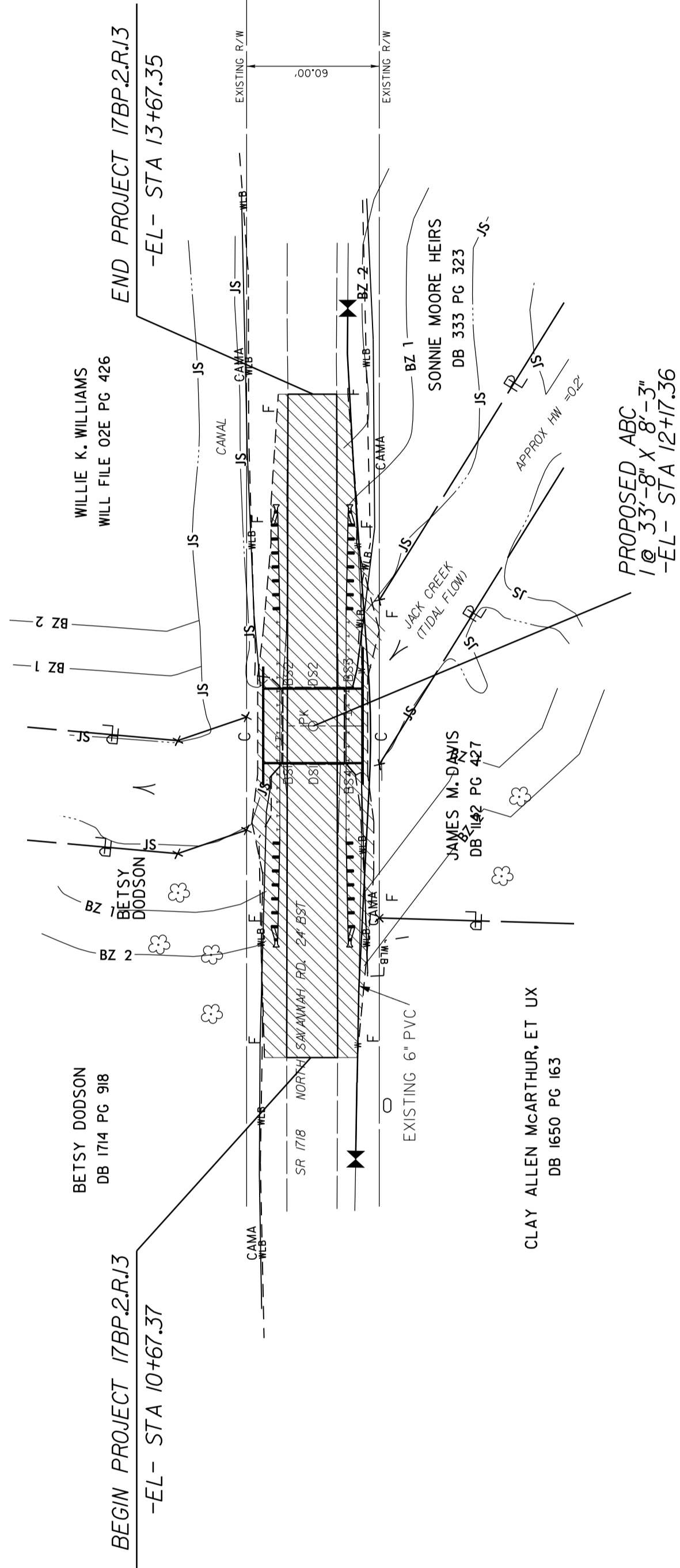
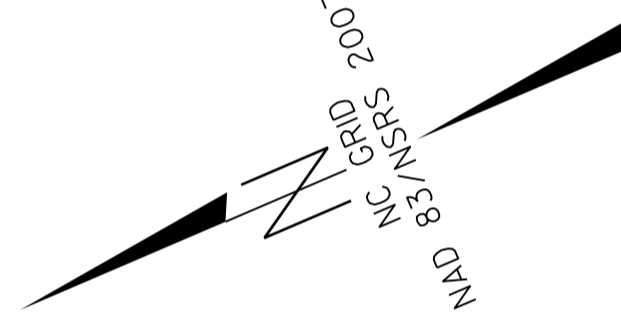

DESIGN DATA

PROJECT LENGTH

LENGTH ROADWAY PROJECT 17BP.2.R.13 = 0.051 MILES
LENGTH STRUCTURE PROJECT 17BP.2.R.13 = 0.006 MILES
TOTAL LENGTH PROJECT 17BP.2.R.13 = 0.057 MILES

Prepared in the Office of:

DIVISION OF HIGHWAYS
1704 N. GREENE ST. GREENVILLE NC, 27835

RIGHT OF WAY DATE: DWAYNE ALLIGOOD
PROJECT ENGINEER

LETTING DATE: February 2013
LANG JONES
PROJECT DESIGN ENGINEER

UTILITIES ENGINEER

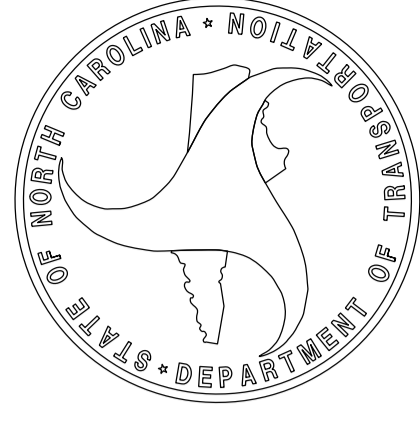
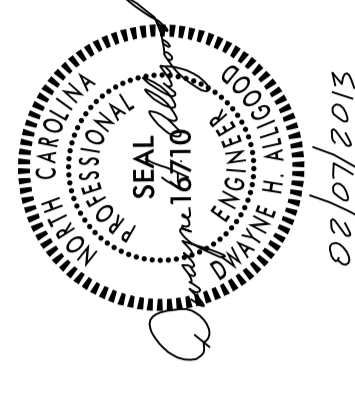

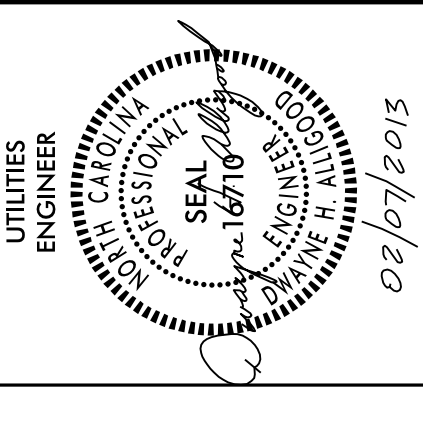

UTILITY CONSTRUCTION

STATE OF NORTH CAROLINA DIVISION OF HIGHWAYS SUMMARY OF QUANTITIES

| WATER MAIN | QUANTITY | UNIT | ITEM DESCRIPTION |
|------------|----------|-------|------------------------------|
| | 40 | LF | 6" DI PIPE |
| | 326 | LF | 8" HDPE PIPE DR9 (AWWA C906) |
| | 2 | EA | 6" GATE VALVE AND VALVE BOX |
| | 2 | EA | DI PIPE TO HDPE TRANSITION |
| | 2 | EA | CONCRETE THRUST COLLAR |
| | 100 | LF | TEMPORARY SILT FENCE |
| | -2 | ACRES | SEEDING AND MULCHING |

REVISIONS

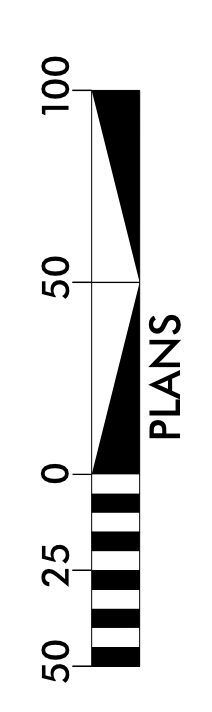
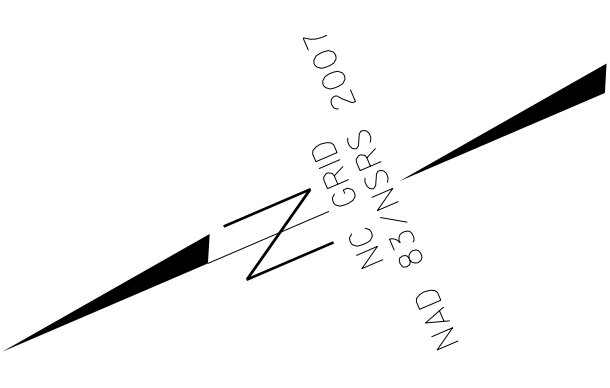

NOTES:
WATER MAIN

1. 8" HDPE WATER MAIN TO CONFORM TO THE FOLLOWING: AWWA C906, PRESSURE CLASS 200, DR9, DUCTILE IRON PIPE SIZE (DIPS) DIMENSIONS, AND MATERIAL DESIGNATION PE 3408 AND NSF APPROVED FOR POTABLE WATER.
2. THE PROPOSED WATER MAIN RELOCATION DOES NOT IMPACT ANY ENVIRONMENTALLY SENSITIVE AREAS.
3. LOCATION AND ELEVATION OF ALL UNDERGROUND UTILITIES SHALL BE FIELD VERIFIED BY CONTRACTOR AND MAINTAIN 18" MINIMUM VERTICAL SEPARATION.

LEGEND:

- Gate Valve
- HDPE to DIP Transition
- Thrust Collar

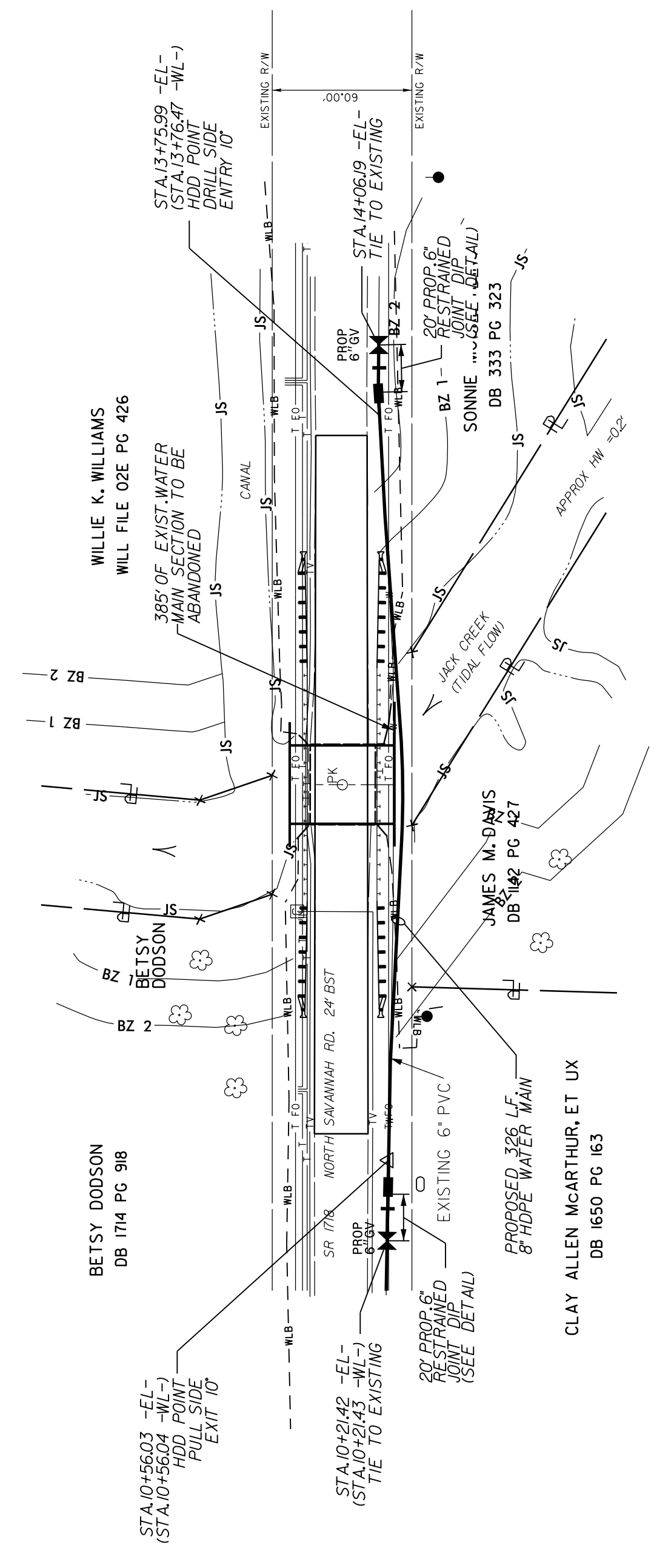

DATUM DESCRIPTION
 THE LOCALIZED COORDINATE SYSTEM DEVELOPED FOR THIS PROJECT IS BASED ON THE STATE PLANE COORDINATES ESTABLISHED BY NC007 FOR MONUMENT "BL1" WITH NAD 83/NSRS 2007 STATE PLANE GRID COORDINATES OF NORTHING: 637043.228(ft) EASTING: 2693804.837(ft) ELEVATION: 2.732(ft)
 THE AVERAGE COMBINED GRID FACTOR USED ON THIS PROJECT (GROUND TO GRID) IS: 0.999886050
 THE N.C. LAMBERT GRID BEARING AND LOCALIZED HORIZONTAL GROUND DISTANCE FROM "BL1" TO -EL- STATION 10+00.00 IS N 53°13'35.6"E 20.51'
 ALL LINEAR DIMENSIONS ARE LOCALIZED HORIZONTAL DISTANCES VERTICAL DATUM USED IS NAVD 88

PROFILE ALONG PROPOSED WATER MAIN

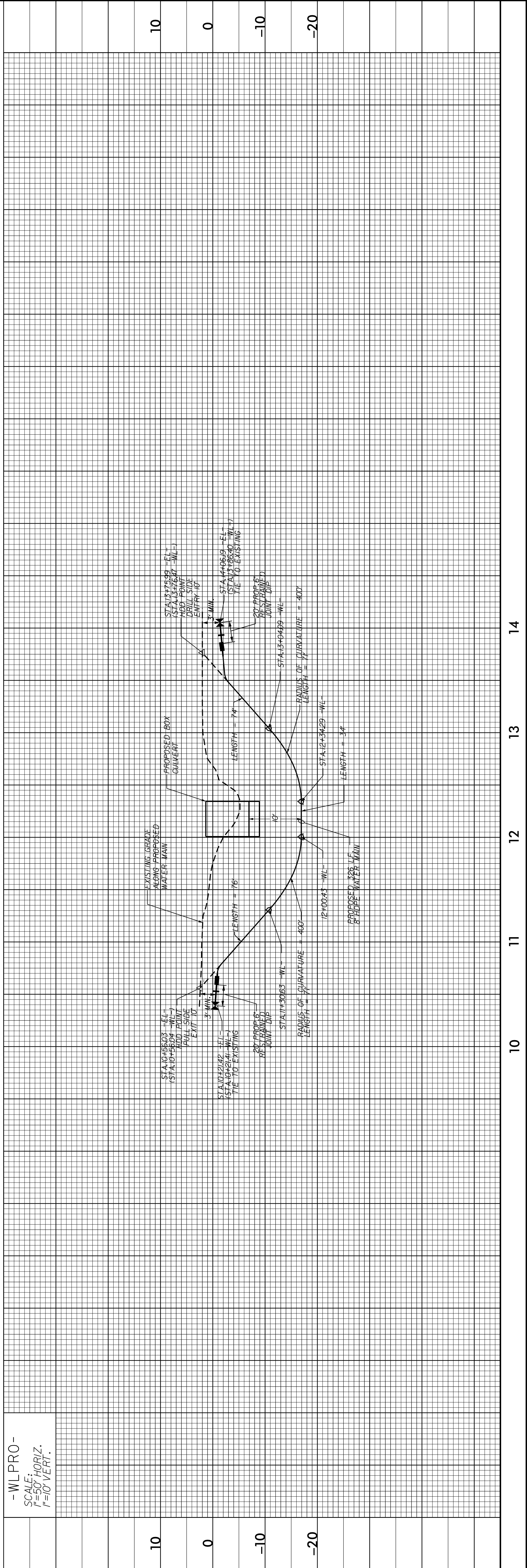

REVISIONS

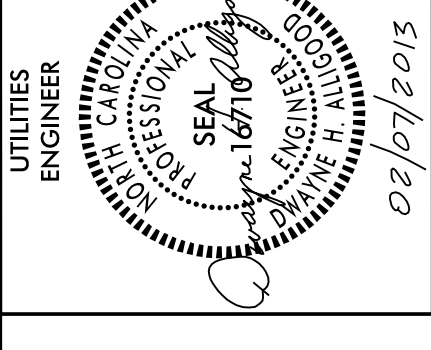

UTILITY CONSTRUCTION DETAIL SHEET

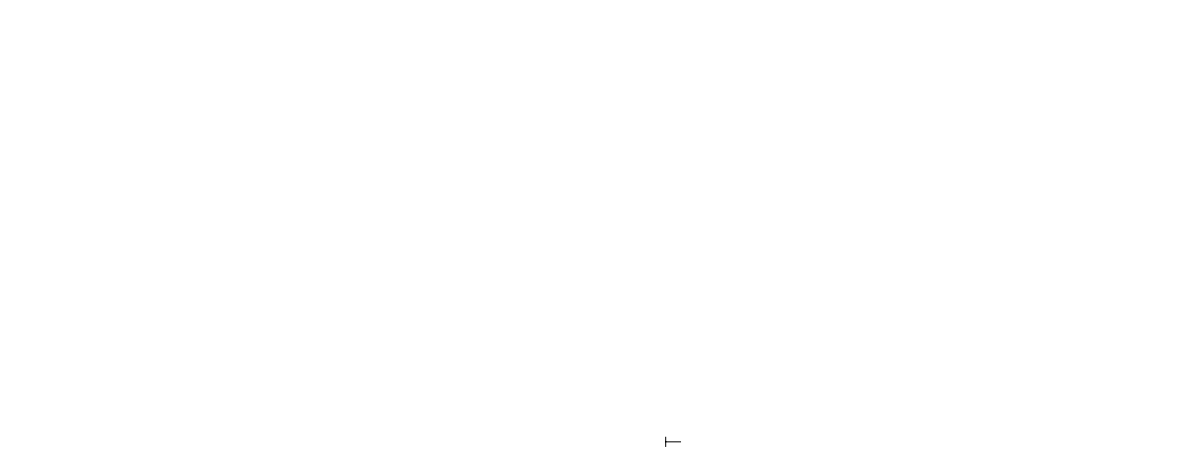
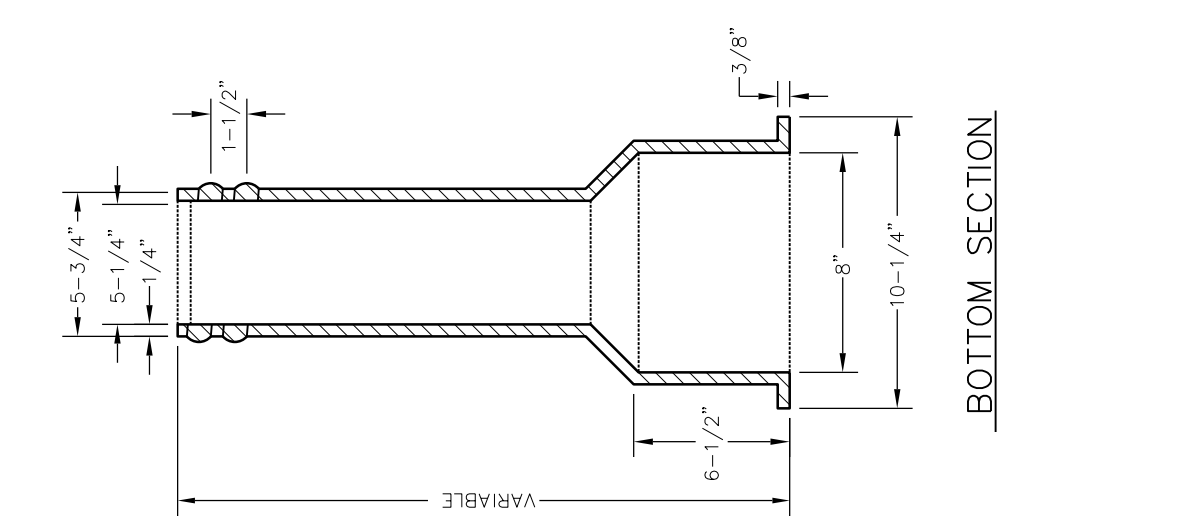
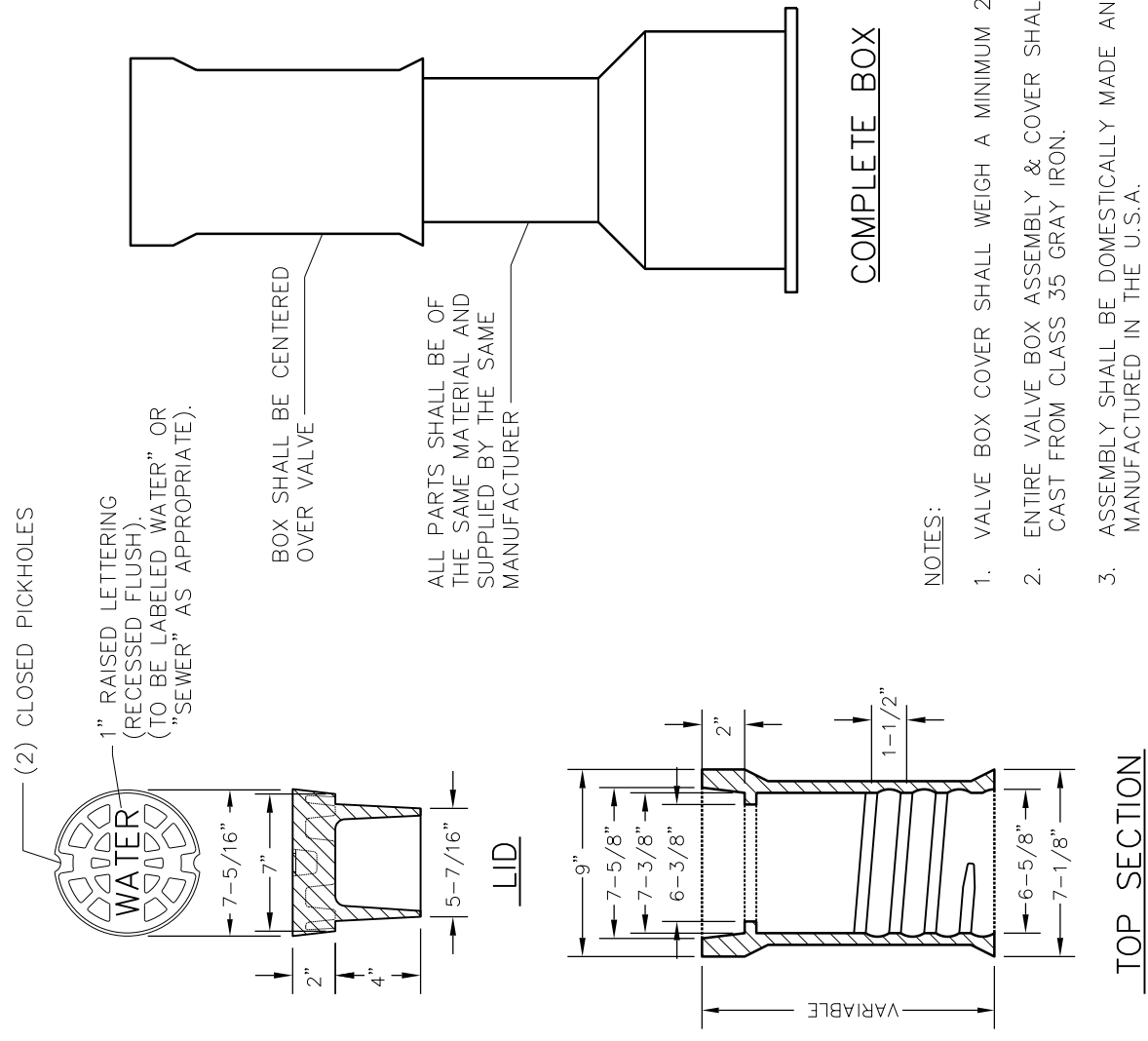

TYPICAL VALVE BOX
NTS

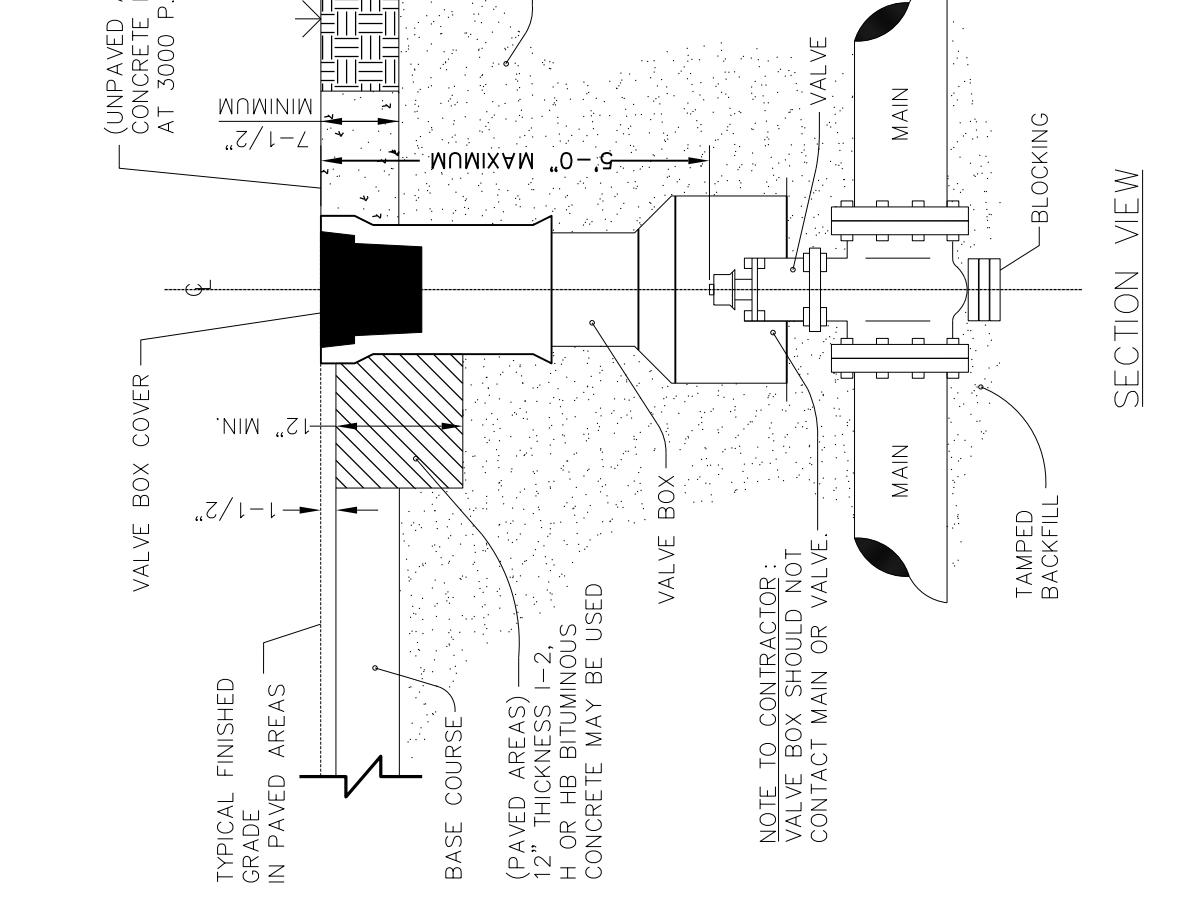
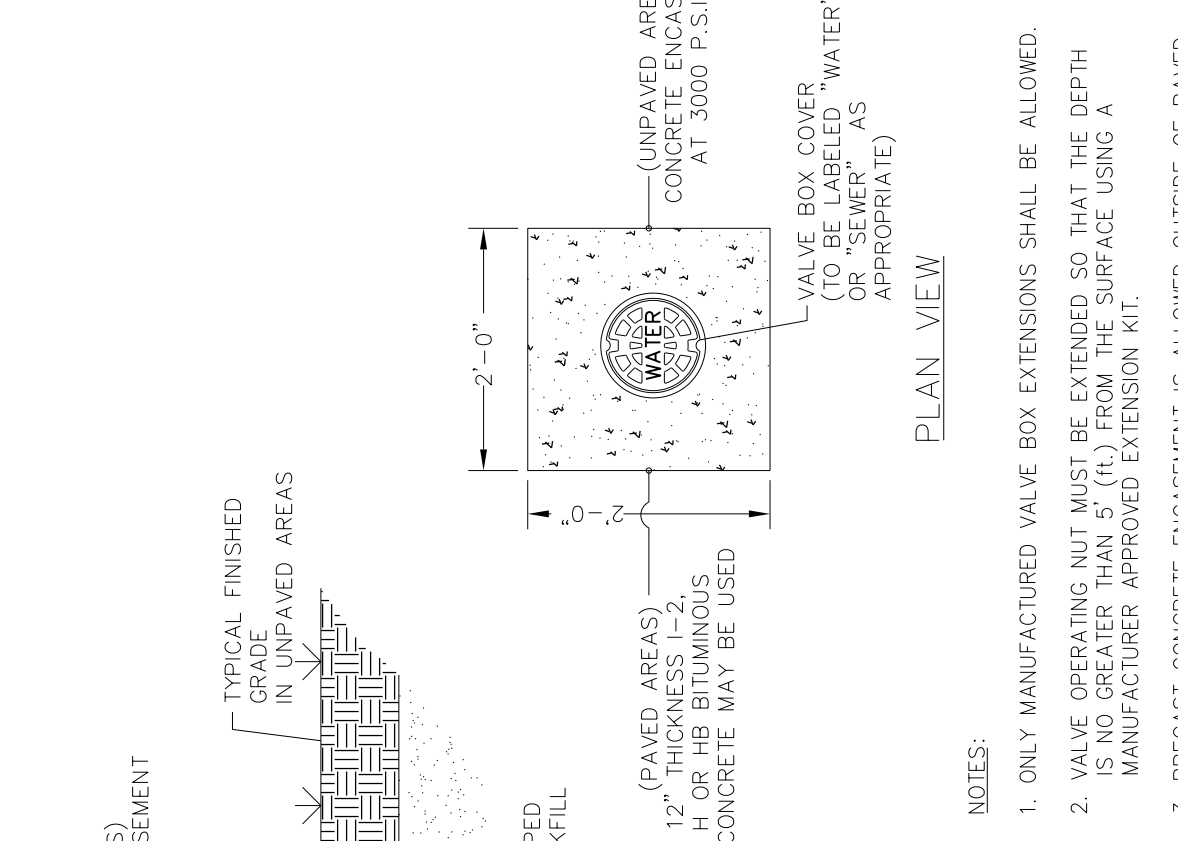

TYPICAL VALVE BOX
NTS

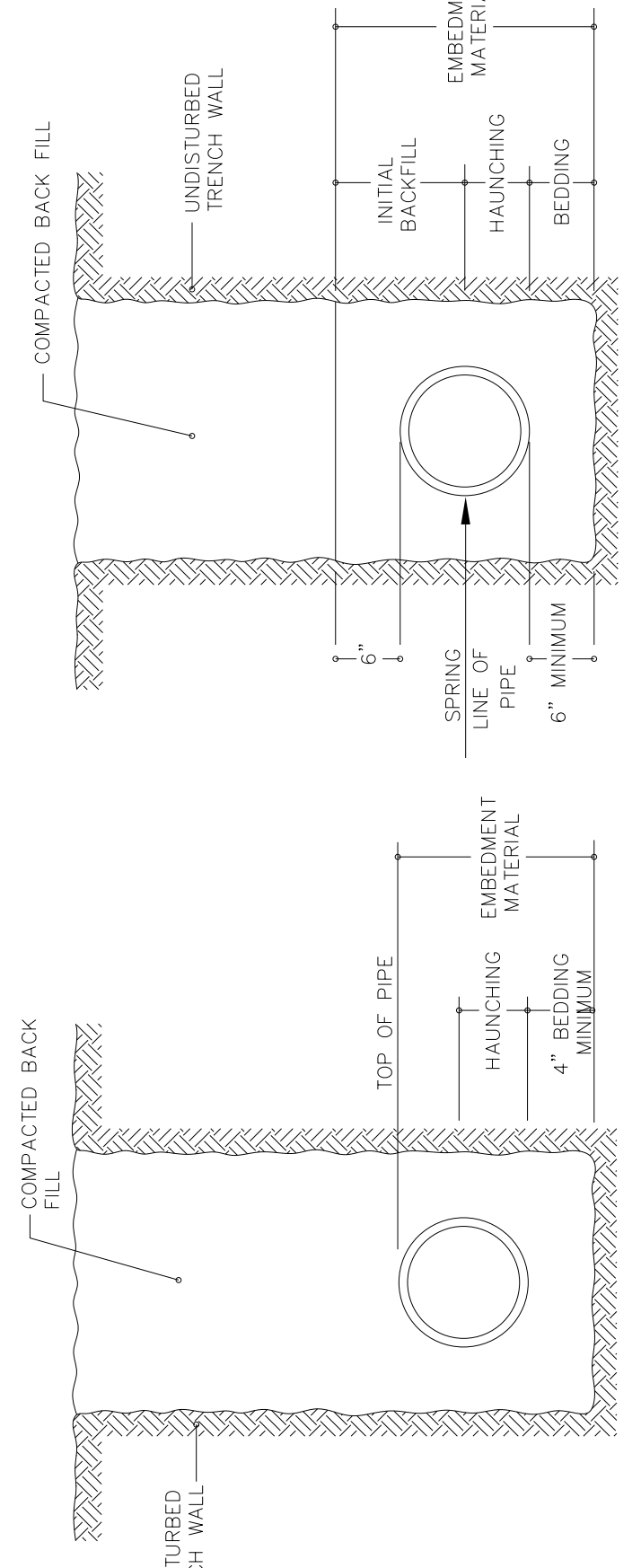
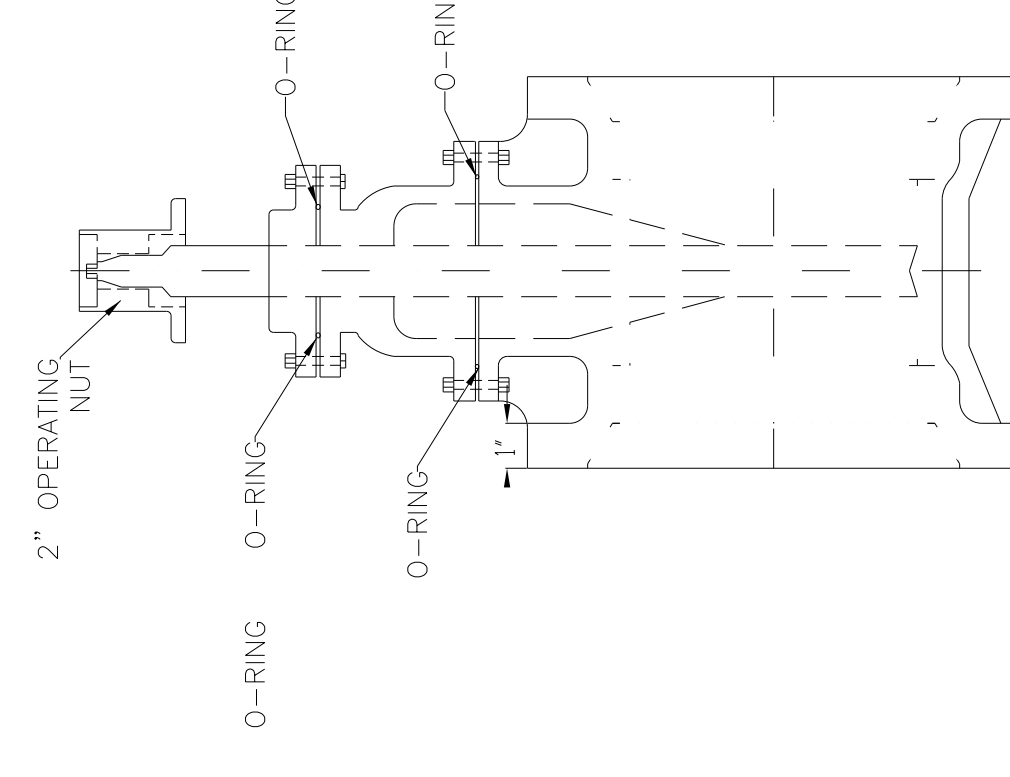

- NOTES:
1. EMBEDMENT MATERIAL MUST BE CLASS 1 (ND, 67 OR ND, 78M WASHED STONE IS TYPICALLY USED).
 2. EMBEDMENT MATERIAL SHALL BE COMPACTED TO A MINIMUM 95% STANDARD PROCTOR DENSITY FOR CLASS 1 MATERIAL.
 3. STANDARD BEDDING SHALL BE UTILIZED FOR ALL CASES WHERE TRENCH BOTTOMS ARE UNSTABLE DUE TO SOIL TYPE, OR MOISTURE CONDITIONS.

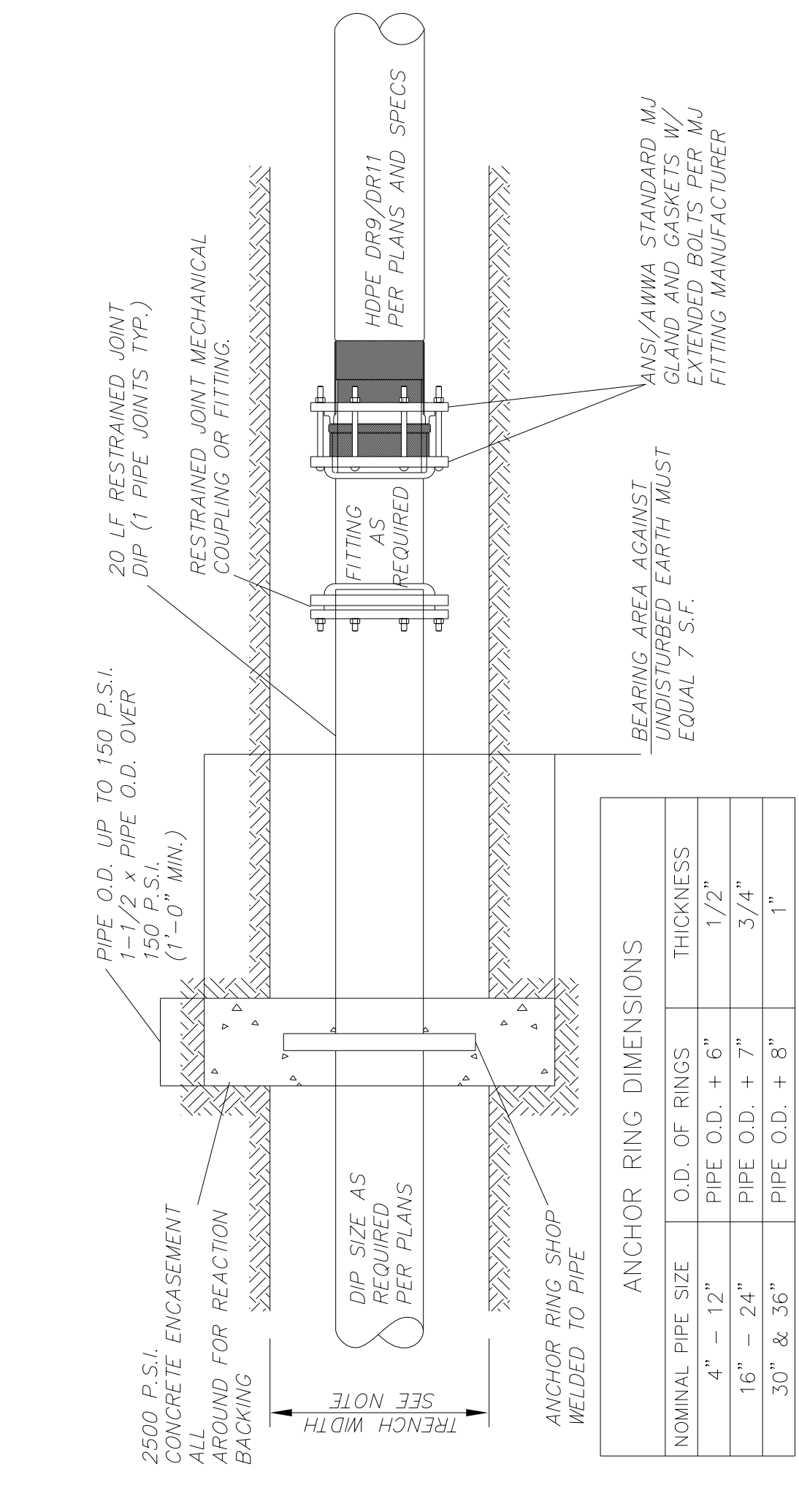

TYPICAL RESILIENT MECHANICAL JOINT GATE VALVE DETAIL
NTS

TYPICAL BEDDING FOR FLEXIBLE & SEMI-RIGID PIPE
NTS

TYPICAL DIP TO HDPE TRANSITION DETAIL WITH THRUST COLLAR
NTS

STATE OF NORTH CAROLINA
DIVISION OF HIGHWAYS

TRANSPORTATION MANAGEMENT PLAN
BEAUFORT COUNTY

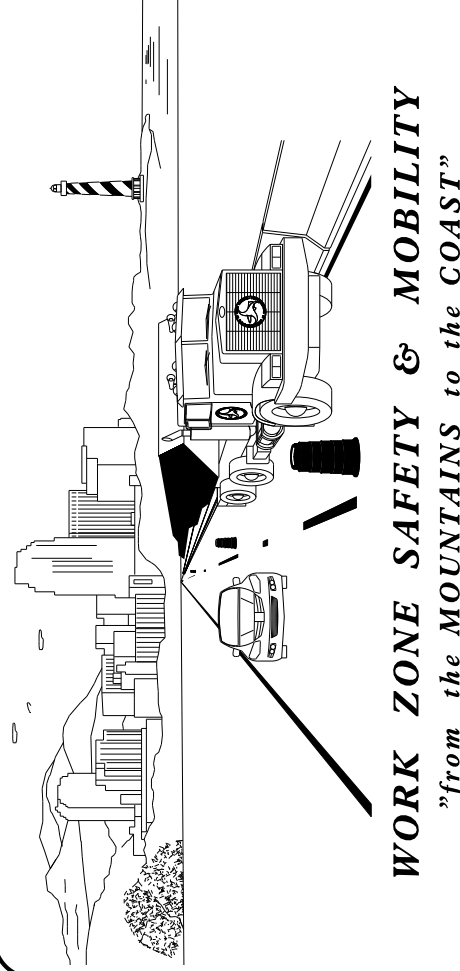
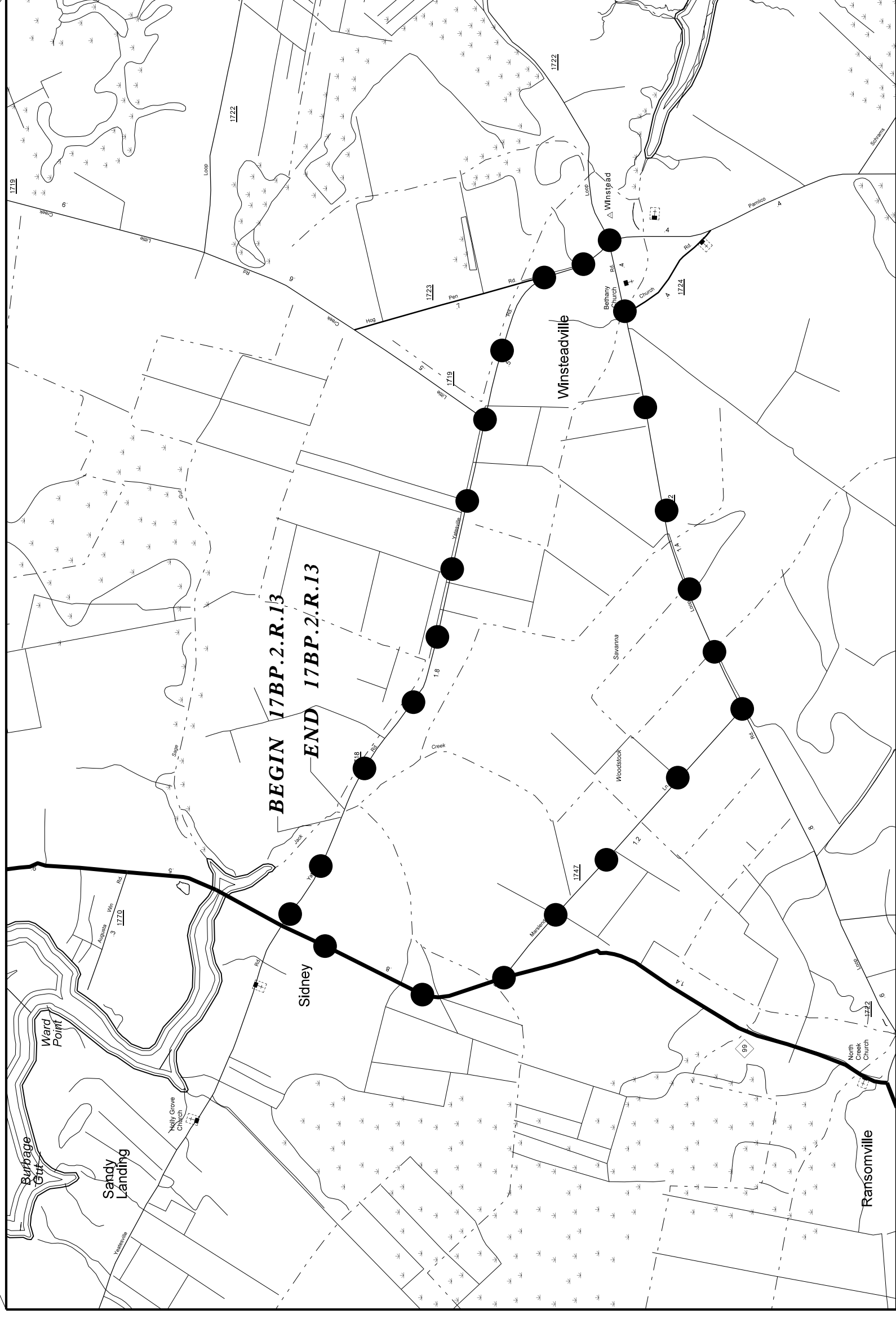
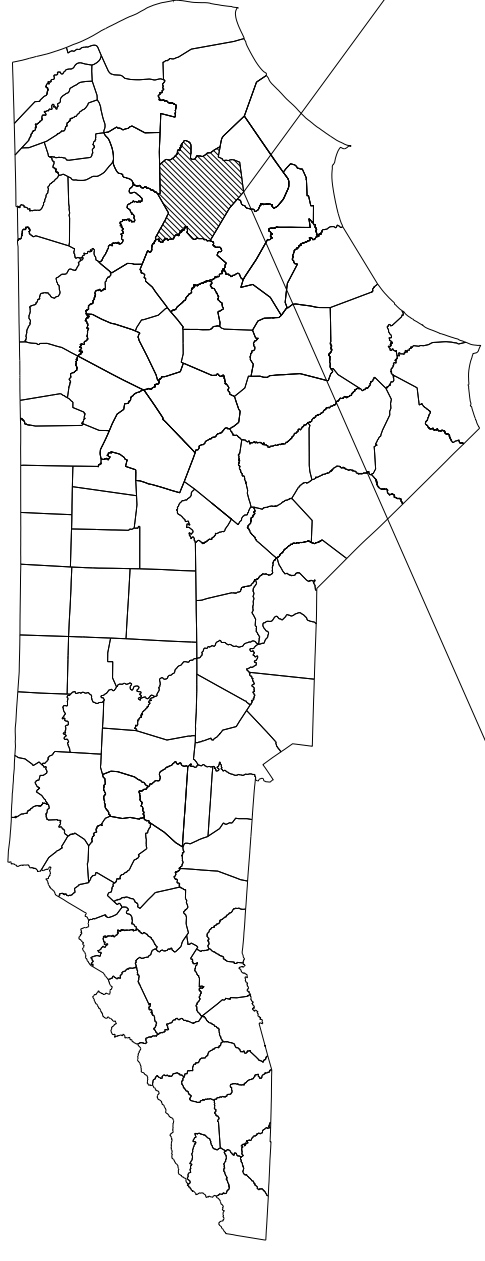

N.C.D.O.T. DIVISION TWO DDC
1704 N. GREENE ST.
GREENVILLE, NC 27835
PHONE 252-439-2800

DWAYNE ALLIGOOD _____ TRAFFIC CONTROL PROJECT ENGINEER
LANG JONES _____ TRAFFIC CONTROL PROJECT DESIGN ENGINEER
LANG JONES _____ TRAFFIC CONTROL DESIGN ENGINEER



APPROVED: *Quayle H. Allgood*
DATE: *02/07/2013*

SEAL

INDEX OF SHEETS

| SHEET NO. | TITLE |
|-----------|--|
| TMP-1 | TITLE SHEET, VICINITY MAP & INDEX OF SHEETS; LIST OF APPLICABLE ROADWAY STANDARD DRAWINGS & LEGEND |
| TMP-2 | PROJECT NOTES, DETOUR AND PLANS. |

ROADWAY STANDARD DRAWINGS

THE FOLLOWING ROADWAY STANDARDS AS SHOWN IN "ROADWAY STANDARD DRAWINGS" - PROJECT SERVICES UNIT - N.C. DEPARTMENT OF TRANSPORTATION - RALEIGH, N.C., DATED JANUARY 2012 ARE APPLICABLE TO THIS PROJECT AND BY REFERENCE HEREBY ARE CONSIDERED A PART OF THESE PLANS:

| STD. NO. | TITLE |
|----------|---|
| 1101.01 | WORK ZONE WARNING SIGNS |
| 1101.02 | TEMPORARY LANE CLOSURES |
| 1101.03 | TEMPORARY ROAD CLOSURES |
| 1101.04 | TEMPORARY SHOULDER CLOSURES |
| 1101.05 | WORK ZONE VEHICLE ACCESSES |
| 1101.06 | WARNING SIGNS FOR BLASTING ZONES |
| 1101.11 | TRAFFIC CONTROL DESIGN TABLES |
| 1110.01 | STATIONARY WORK ZONE SIGNS |
| 1110.02 | PORTABLE WORK ZONE SIGNS |
| 1115.01 | FLASHING ARROW BOARDS |
| 1130.01 | DRUMS |
| 1135.01 | CONES |
| 1145.01 | BARRICADES |
| 1150.01 | FLAGGING DEVICES |
| 1160.01 | TEMPORARY CRASH CUSHION |
| 1165.01 | WORK VEHICLE LIGHTING SYSTEMS AND TMA DELINEATION |
| 1170.01 | PORTABLE CONCRETE BARRIER |
| 1180.01 | SKINNY - DRUM |

LEGEND

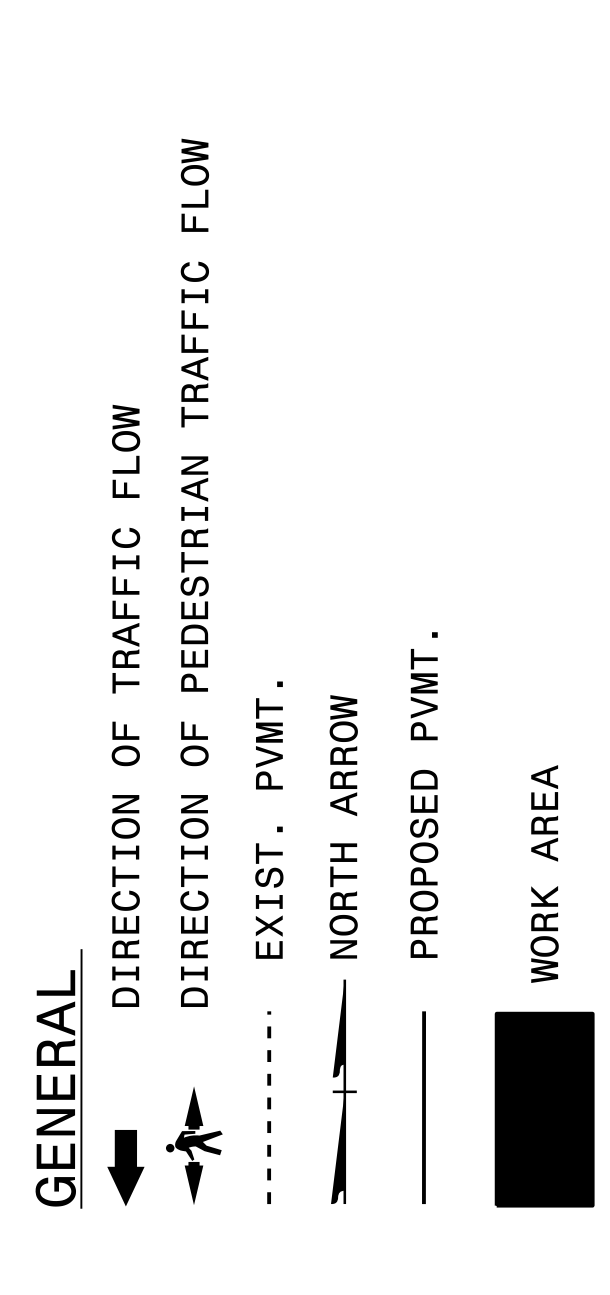

TRAFFIC CONTROL DEVICES

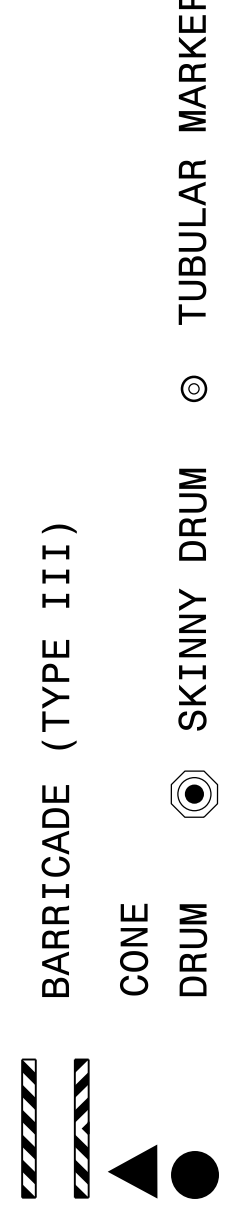

PROJECT:

17BP.2.R.13

SHEET NO.
TMP-1

GENERAL NOTES

IMPLEMENT TRAFFIC CONTROL IN ACCORDANCE WITH THE ROADWAY STANDARD DRAWINGS LISTED ON TMP-1.

CHANGES MAY BE REQUIRED WHEN PHYSICAL DIMENSIONS IN THE DETAIL DRAWINGS, STANDARD DETAILS AND ROADWAY DETAILS ARE NOT ATTAINABLE TO MEET FIELD CONDITIONS, OR RESULT IN DUPLICATE, OR UNDESIRABLE OVERLAPPING OF DEVICES. MODIFICATION MAY INCLUDE: MOVING, SUPPLEMENTING, COVERING OR REMOVAL OF DEVICES, AS DIRECTED BY THE ENGINEER.

STATE FORCES WILL INSTALL AND MAINTAIN THE PROJECT DETOUR AND THE TYPE III BARRICADES AT THE PROJECT LIMITS.
 STATE FORCES WILL INSTALL PAINT AND MARKERS ON THE FINISHED PROJECT.
 CALL JIM EVANS AT 252-830-3493 FOR COORDINATION.

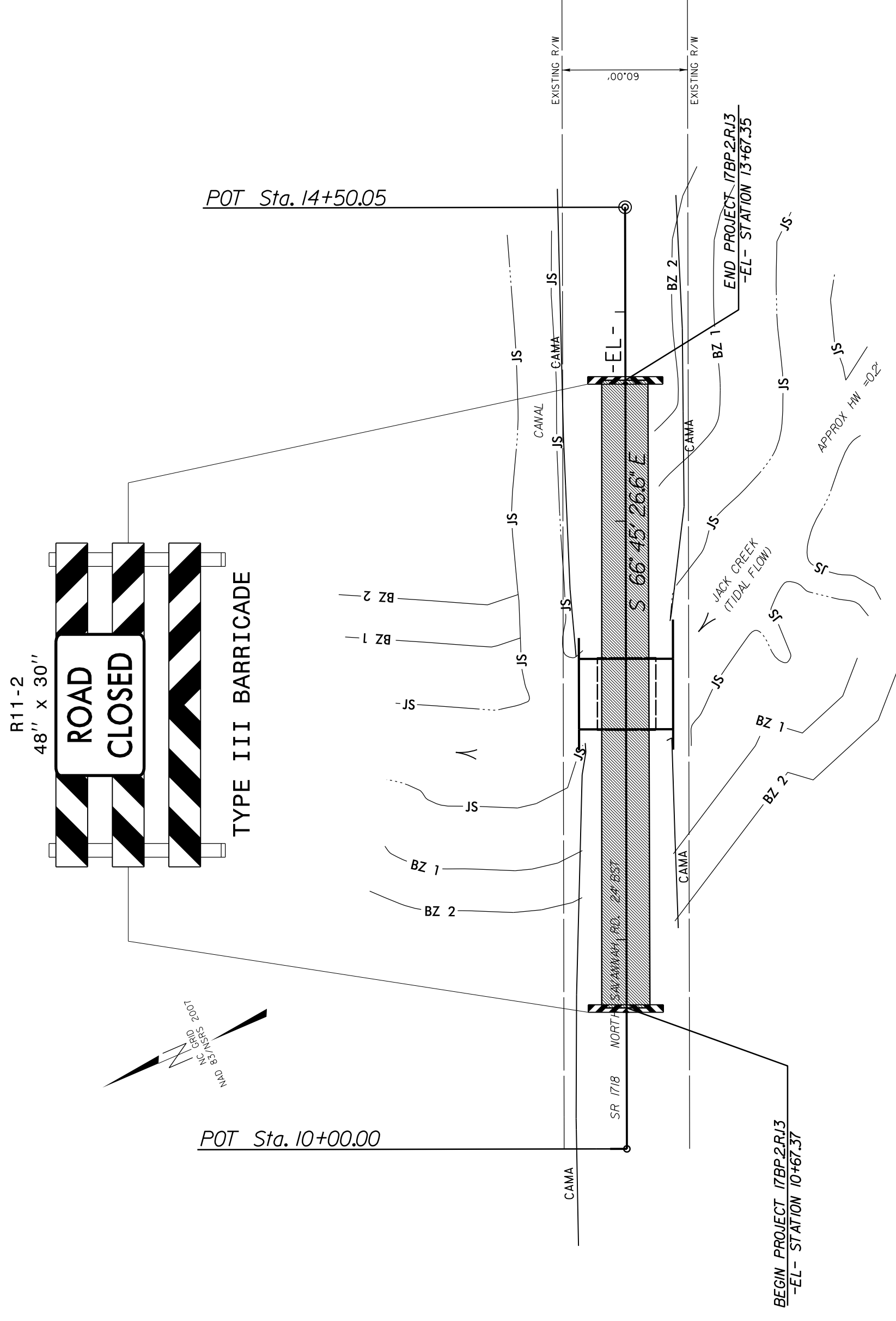
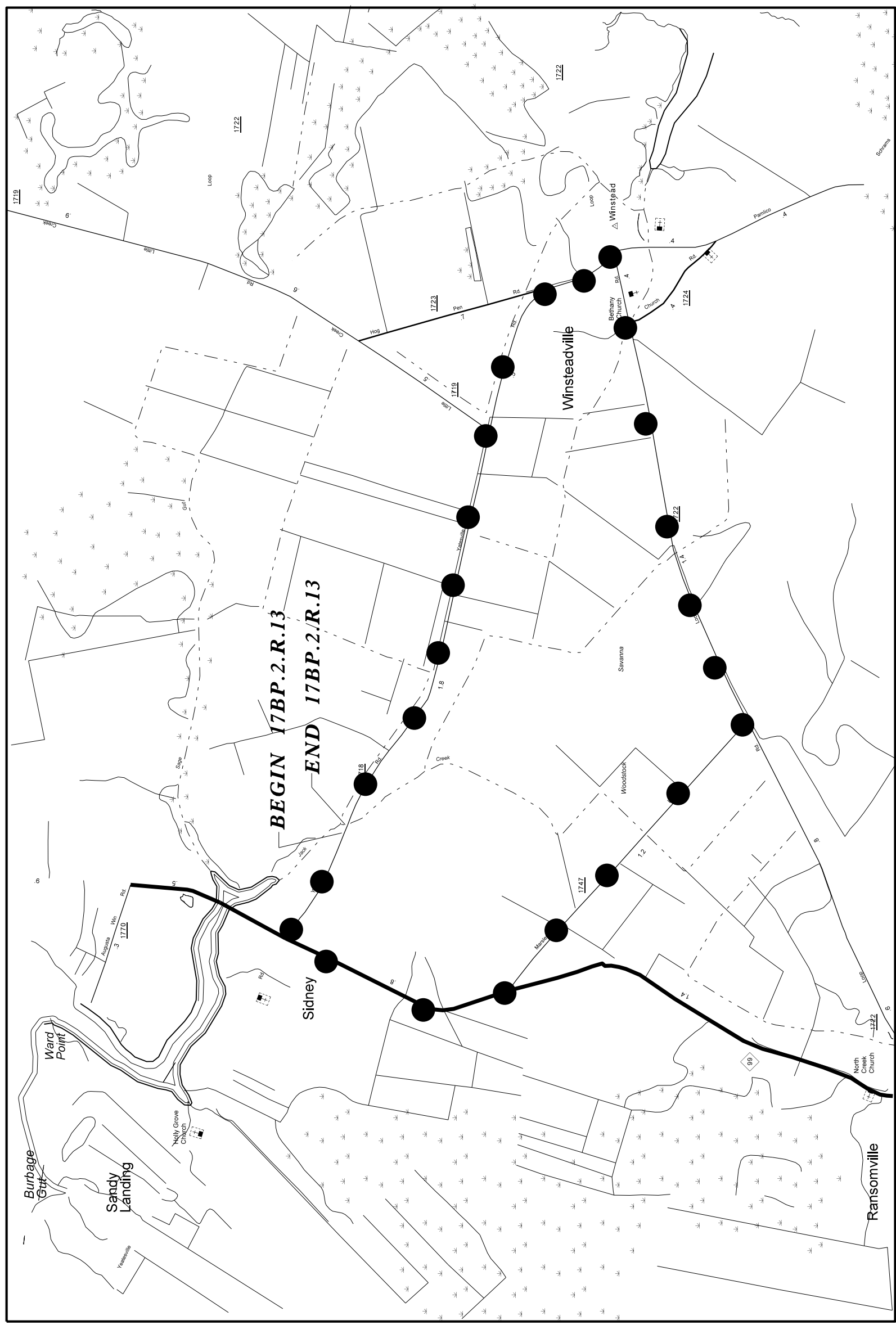

APPROVED *Designer of Record* DATE: 2/26/2015

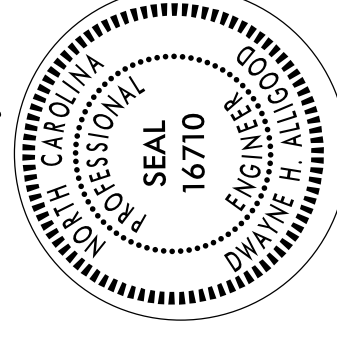

SEAL



PROJECT: 17BP.2.R.13

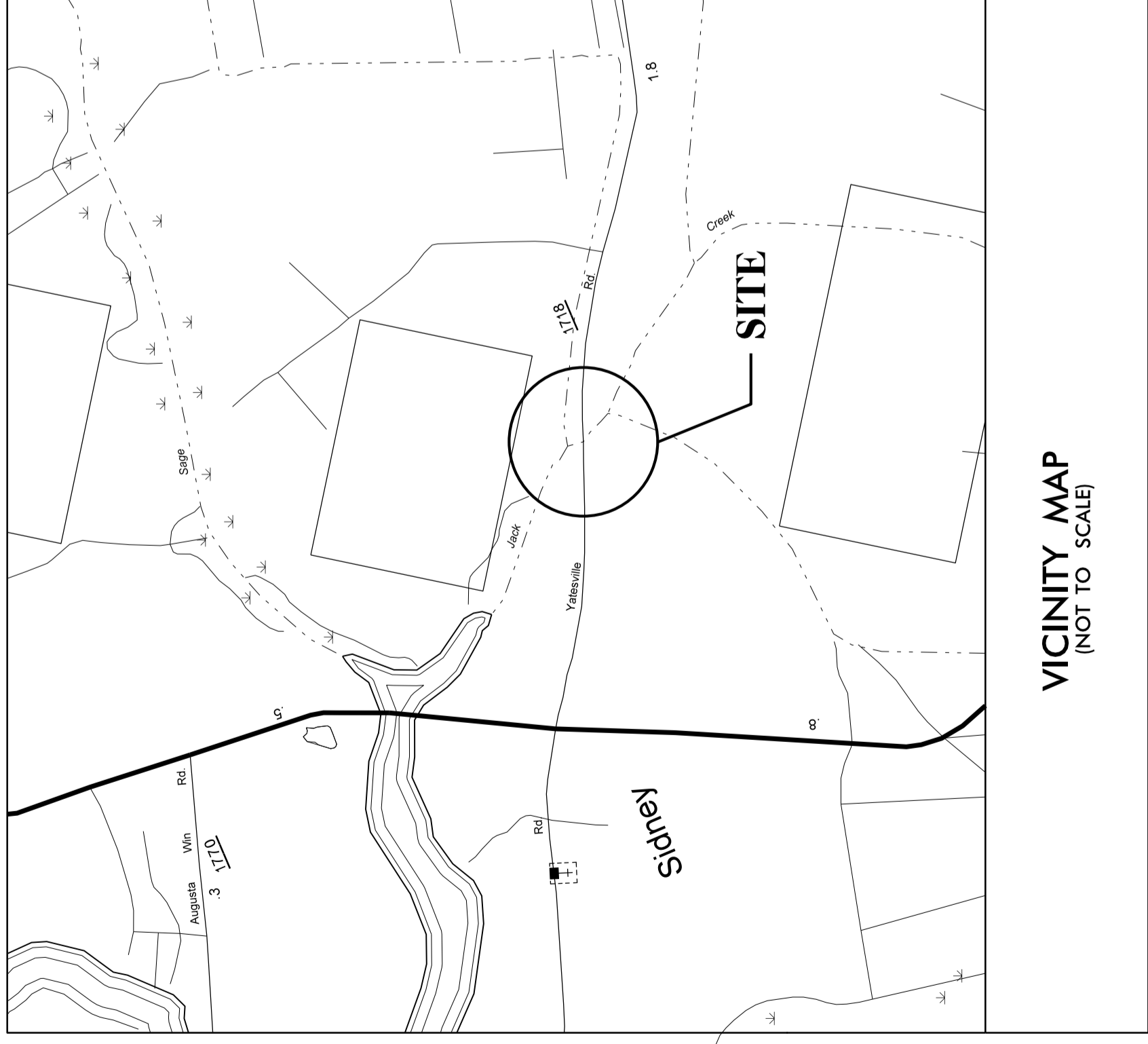

STATE OF NORTH CAROLINA DIVISION OF HIGHWAYS PLAN FOR PROPOSED HIGHWAY EROSION CONTROL

| | | | |
|-----------------|-----------------------------|-------------|--------------|
| STATE | STATE PROJECT REFERENCE NO. | SHEET NO. | TOTAL SHEETS |
| N.C. | 17BP.2.R.13 | EC-1 | |
| STATE PROJ. NO. | F.A. PROJ. NO. | DESCRIPTION | |
| | | | |

EROSION AND SEDIMENT CONTROL MEASURES

| Std. # | Description | Symbol |
|---------|--|--------|
| 1650.03 | Temporary Silt Ditch | --- TD |
| 1630.05 | Temporary Diversion | --- TD |
| 1605.01 | Temporary Silt Fence | --- SF |
| 1606.01 | Special Sediment Control Fence | --- SF |
| 1622.01 | Temporary Berms and Slope Drains | --- TD |
| 1630.02 | Silt Basin Type B | --- SB |
| 1633.01 | Temporary Rock Silt Check Type-A | --- RC |
| | Temporary Rock Silt Check Type-A with Matting and Polyacrylamide (PAM) | --- RC |
| 1633.02 | Temporary Rock Silt Check Type-B | --- RC |
| | Wattle/Coir Fiber Wattle | --- WF |
| | Wattle/Coir Fiber Wattle with Polyacrylamide (PAM) | --- WF |
| 1634.01 | Temporary Rock Sediment Dam Type-A | --- RD |
| 1634.02 | Temporary Rock Sediment Dam Type-B | --- RD |
| 1635.01 | Rock Pipe Inlet Sediment Trap Type-A | --- RP |
| 1635.02 | Rock Pipe Inlet Sediment Trap Type-B | --- RP |
| 1630.04 | Stilling Basin | --- SB |
| 1630.06 | Special Stilling Basin | --- SB |
| 1632.01 | Rock Inlet Sediment Trap Type A | --- RI |
| 1632.02 | Type B | --- RI |
| 1632.03 | Type C | --- RI |
| | Skimmer Basin | --- SK |
| | Tiered Skimmer Basin | --- SK |
| | Infiltration Basin | --- IB |

THIS PROJECT CONTAINS
EROSION CONTROL PLANS
FOR CLEARING AND
GRUBBING PHASE OF
CONSTRUCTION.

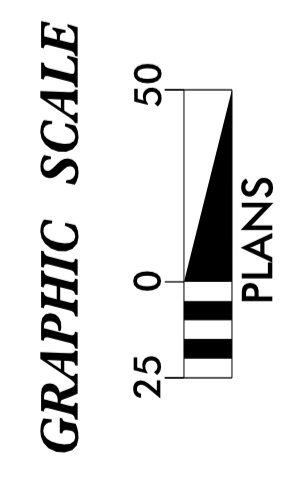
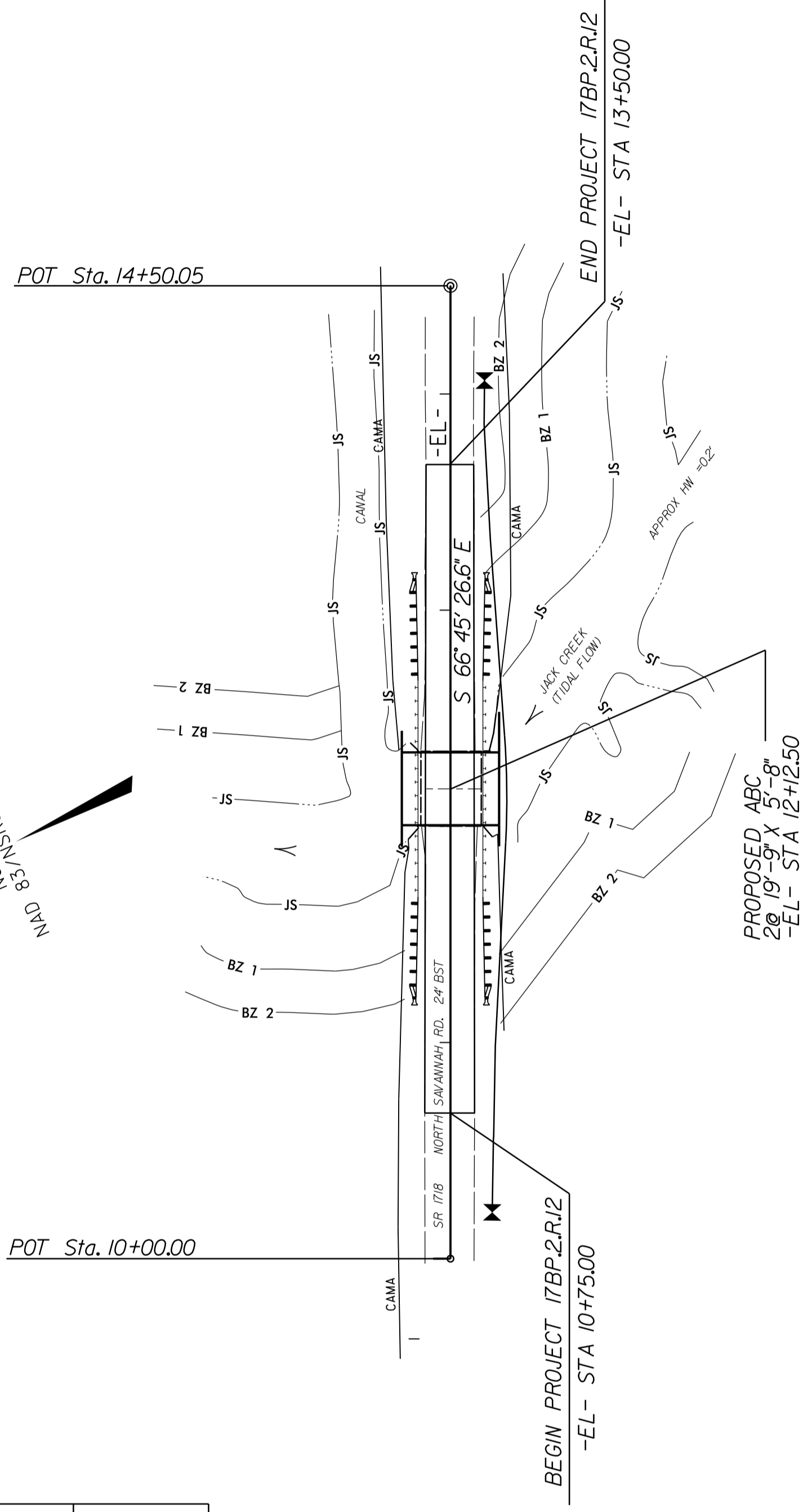

ROADSIDE ENVIRONMENTAL UNIT
DIVISION OF HIGHWAYS
STATE OF NORTH CAROLINA

THESE EROSION AND SEDIMENT CONTROL PLANS COMPLY
WITH THE REGULATIONS SET FORTH BY THE
NCG-010000 GENERAL CONSTRUCTION PERMIT EFFECTIVE AUGUST 3, 2011
ISSUED BY THE NORTH CAROLINA DEPARTMENT OF ENVIRONMENT AND
NATURAL RESOURCES DIVISION OF WATER QUALITY.

2012 STANDARD SPECIFICATIONS

Prepared in the Office of:
DIVISION 2 DDC
1704 NORTH GREENE STREET
GREENVILLE, NC 27835

Lang Jones, DDC Engineer
Level IIIIA
Certification #274

Roadway Standard Drawings

The following roadway english standards as appear in "Roadway Standard Drawings", Roadway Design Unit - N.C. Department of Transportation - Raleigh, N.C., dated January 2012, and the latest revision thereto are applicable to this project and by reference hereby are considered a part of these plans.

| | | | |
|---------|----------------------------------|---------|--------------------------------------|
| 1604.01 | Railroad Erosion Control Detail | 1632.01 | Rock Inlet Sediment Trap Type A |
| 1605.01 | Temporary Silt Fence | 1632.02 | Rock Inlet Sediment Trap Type B |
| 1606.01 | Special Sediment Control Fence | 1632.03 | Rock Inlet Sediment Trap Type C |
| 1607.01 | Gravel Construction Entrance | 1633.01 | Temporary Rock Silt Check Type A |
| 1622.01 | Temporary Berms and Slope Drains | 1633.02 | Temporary Rock Silt Check Type B |
| 1630.01 | Riser Basin | 1634.01 | Temporary Rock Sediment Dam Type A |
| 1630.02 | Silt Basin Type B | 1634.02 | Temporary Rock Sediment Dam Type B |
| 1630.03 | Temporary Silt Ditch | 1635.01 | Rock Pipe Inlet Sediment Trap Type A |
| 1630.04 | Stilling Basin | 1635.02 | Rock Pipe Inlet Sediment Trap Type B |
| 1630.05 | Temporary Diversion | 1640.01 | Coir Fiber Baffle |
| 1630.06 | Special Stilling Basin | 1645.01 | Temporary Stream Crossing |
| 1631.01 | Matting Installation | | |

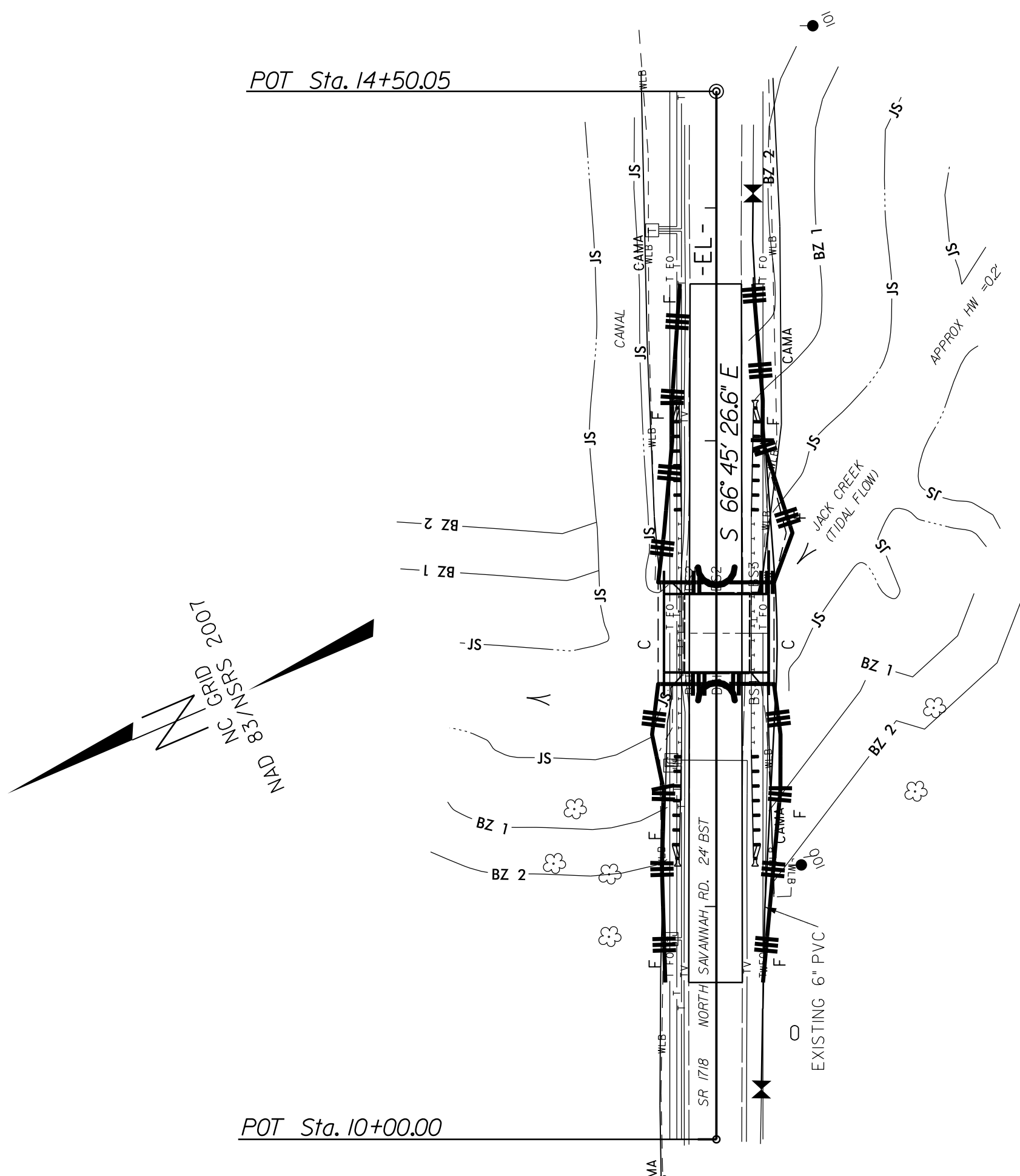
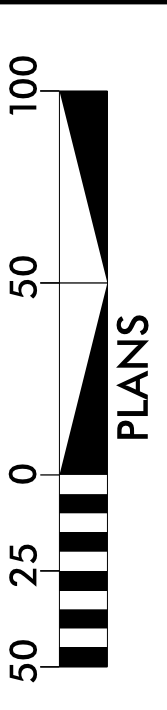

SOIL STABILIZATION TIMEFRAMES

| SITE DESCRIPTION | STABILIZATION TIME | TIMEFRAME EXCEPTIONS |
|--|--------------------|--|
| PERIMETER DIKES, SWALES, DITCHES AND SLOPES | 7 DAYS | NONE |
| HIGH QUALITY WATER (HOW) ZONES | 7 DAYS | NONE |
| SLOPES STEEPER THAN 3:1 | 7 DAYS | IF SLOPES ARE 10' OR LESS IN LENGTH AND ARE NOT STEEPER THAN 2:1, 14 DAYS ARE ALLOWED. |
| SLOPES 3:1 OR FLATTER | 14 DAYS | 7 DAYS FOR SLOPES GREATER THAN 50' IN LENGTH. |
| ALL OTHER AREAS WITH SLOPES FLATTER THAN 4:1 | 14 DAYS | NONE, EXCEPT FOR PERIMETERS AND HOW ZONES. |

| Std. # | Description | Symbol |
|---------|---------------------------------|--------|
| 1605.01 | High Vis Temporary Silt Fence | |
| 1652.03 | Rock Inlet Sediment Trap Type C | |
| SP | Wattle with Polyacrylamide | |
| SP | Wattle | |
| | Ditch Flow Line | |

NOTES: ANY DEVIATION FROM OPTIONS GIVEN WILL REQUIRE PRIOR APPROVAL BY ENGINEER.
ADDITIONAL EROSION CONTROL DEVICES MAY NEED TO BE INSTALLED AS DIRECTED BY THE ENGINEER.
CONTRACTOR SHALL INSTALL SPECIAL SEDIMENT CONTROL FENCE OR WATTLES IN LOW AREAS OF SILT FENCE AS NEEDED OR DIRECTED BY THE ENGINEER.

REVISIONS

08-11-17 10:02 AM
 C:\P\016151\1717\1717\FOR\1717\Beaufort 124\Beaufort14-ec2.dgn
 8/17/99

MATting INSTALLATION DETAIL

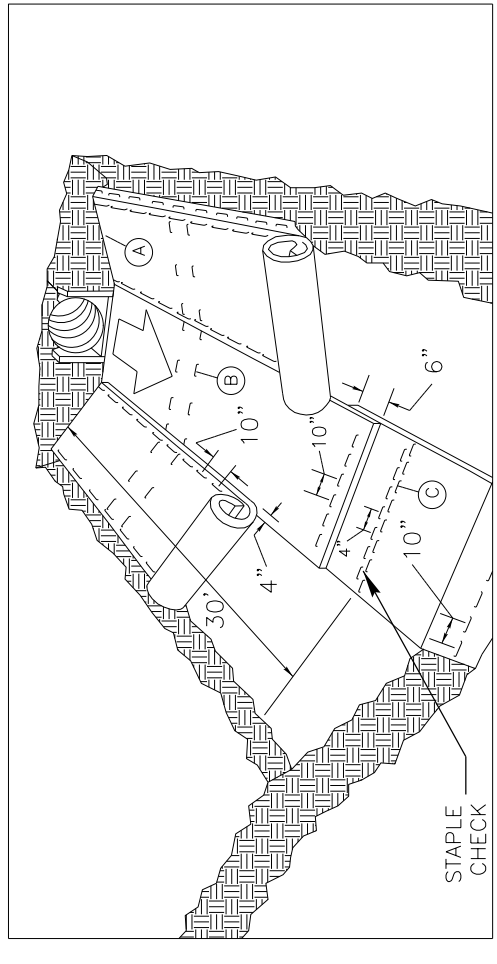
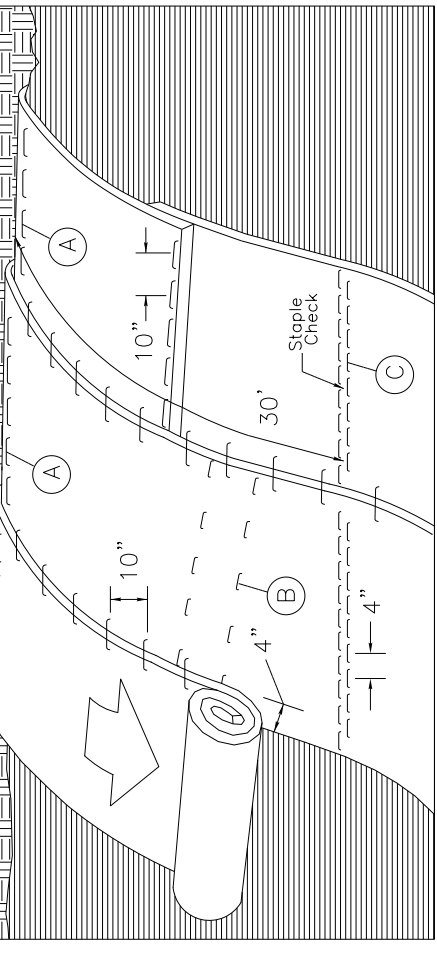

DIAGRAM A



MATting ON SLOPES

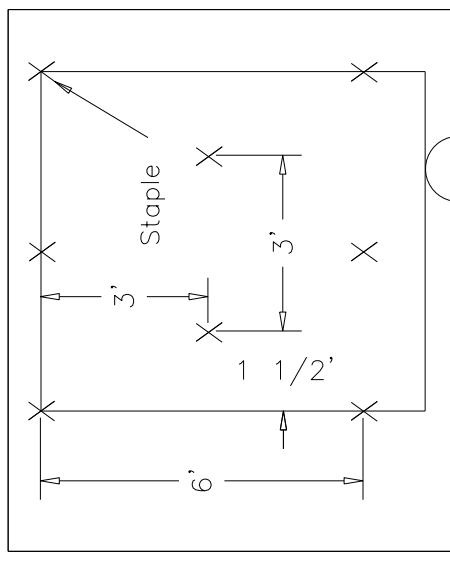

DIAGRAM B

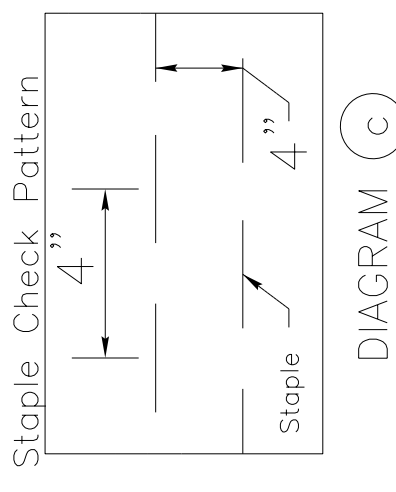
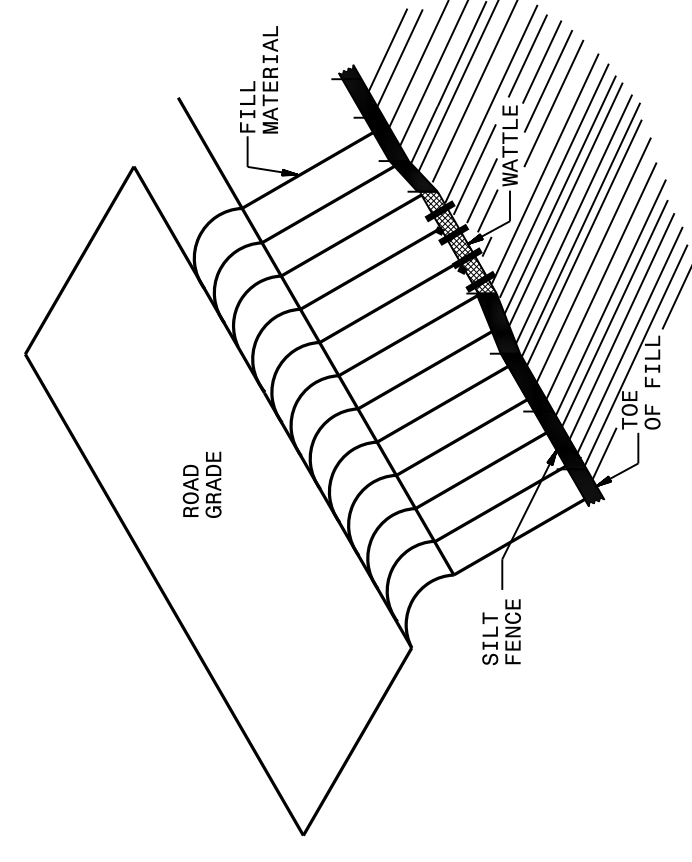

DIAGRAM C

NOTES:
THIS DETAIL APPLIES TO STRAW, EXCELISOR, AND PERMANENT SOIL REINFORCEMENT MAT (PSRM) INSTALLATION. STAPLES SHALL BE NO. 11 GAUGE STEEL WIRE FORMED INTO A "U" SHAPE WITH A MINIMUM THROAT WIDTH OF 1 INCH AND NOT LESS THAN 6 INCHES IN LENGTH.

NOT TO SCALE

SILT FENCE WATTLE BREAK DETAIL



ISOMETRIC VIEW

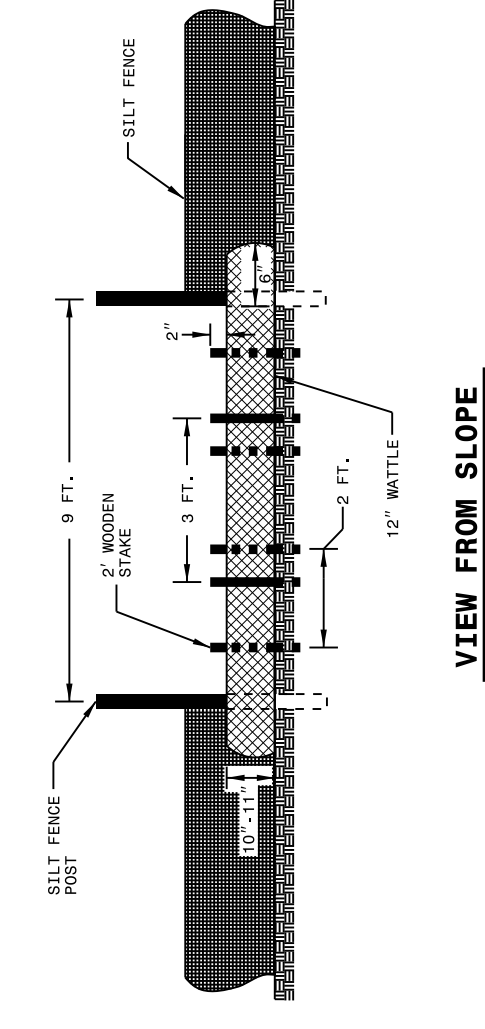
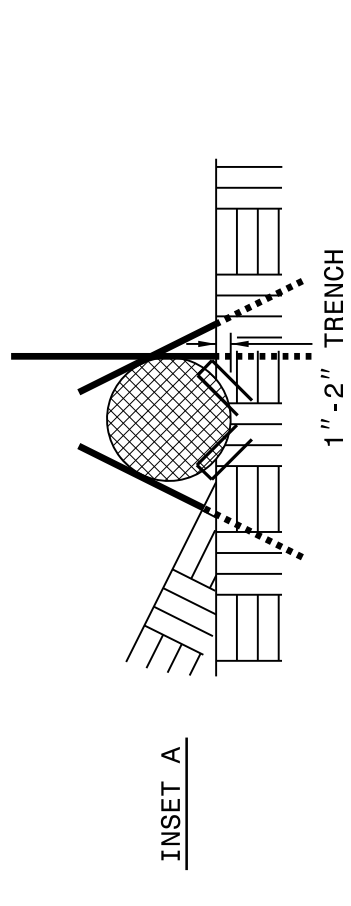

VIEW FROM SLOPE

NOT TO SCALE

NOTES:
USE MINIMUM 12 IN. DIAMETER EXCELISOR WATTLE AND LENGTH OF 10 FT. EXCAVATE A 1 TO 2 INCH TRENCH FOR WATTLE TO BE PLACED.
DO NOT PLACE WATTLE ON TOE OF SLOPE.
USE 2 FT. WOODEN STAKES WITH A 2 IN. BY 2 IN. NOMINAL CROSS SECTION.
INSTALL A MINIMUM OF 2 UPSLOPE STAKES AND 4 DOWNSLOPE STAKES AT AN ANGLE TO WEDGE WATTLE TO GROUND.
PROVIDE STAPLES MADE OF 0.125 IN. DIAMETER STEEL WIRE FORMED INTO A "U" SHAPE NOT LESS THAN 12 IN LENGTH. STAPLES SHALL BE FORMED INTO WATTLE AND AT EACH END TO SECURE IT TO THE SOIL.
WATTLE INSTALLATION CAN BE ON OUTSIDE OF THE SILT FENCE AS DIRECTED.
INSTALL TEMPORARY SILT FENCE IN ACCORDANCE WITH SECTION 1605 OF THE STANDARD SPECIFICATIONS.

STATE OF NORTH CAROLINA
DEPT. OF TRANSPORTATION
DIVISION OF HIGHWAYS
RALEIGH, N.C.

ENGLISH STANDARD DRAWING FOR
TEMPORARY SILT FENCE

SHEET 1 OF 1
1605.01

STATE OF NORTH CAROLINA
DEPT. OF TRANSPORTATION
DIVISION OF HIGHWAYS
RALEIGH, N.C.

ENGLISH STANDARD DRAWING FOR
TEMPORARY SILT FENCE

SHEET 1 OF 1
1605.01

NOTES
USE WIRE A MINIMUM OF 32" IN WIDTH AND WITH A MINIMUM OF 6 LINE WIRES WITH 12" STAY SPACING.
USE FILTER FABRIC A MINIMUM OF 36" IN WIDTH AND FASTEN ADEQUATELY TO THE WIRE AS DIRECTED BY THE ENGINEER.
PROVIDE 5'-0" STEEL POST OF THE SELF-FASTENER ANGLE STEEL TYPE.

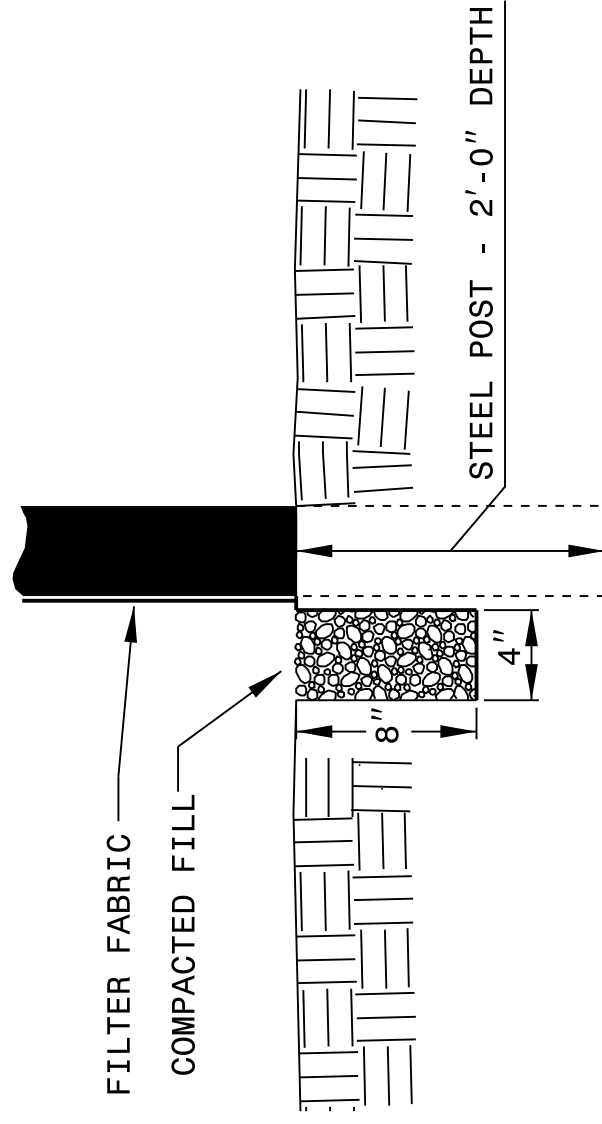
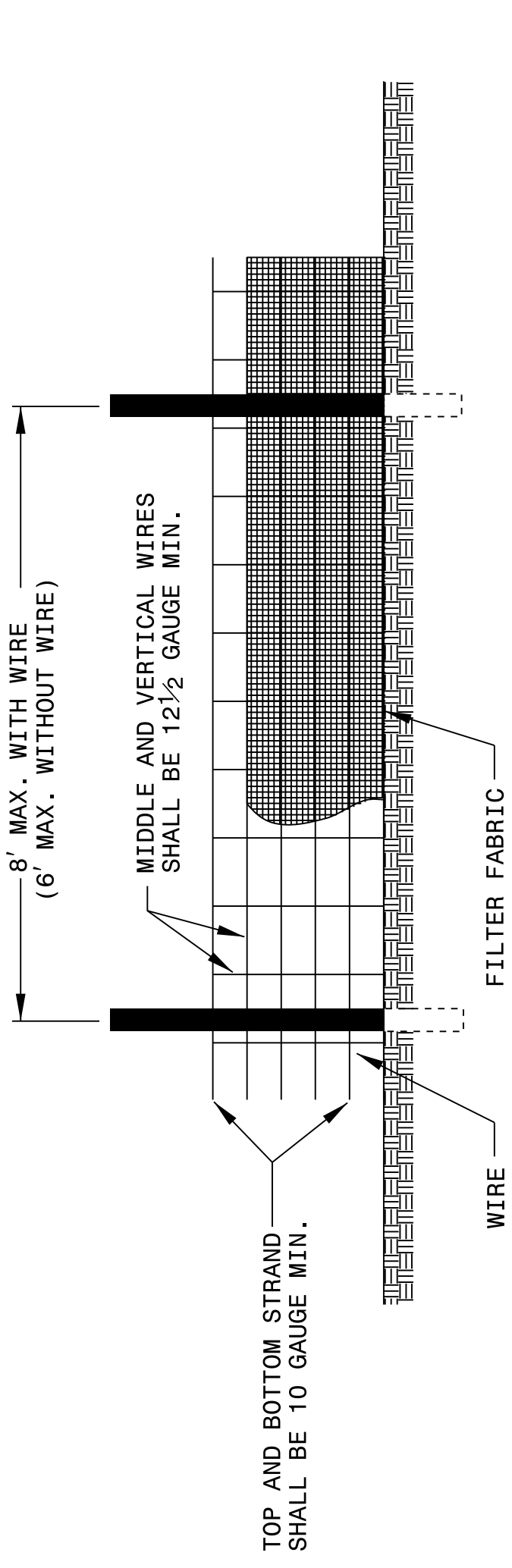

EXTENSION OF FABRIC AND WIRE INTO TRENCH

REVISIONS

DIVISION OF HIGHWAYS
STATE OF NORTH CAROLINA

CROSS-SECTION SUMMARY

IN CUBIC YARDS

| LOCATION (+/-) | UNCLASSIFIED EXCAVATION | UNDERCUT | EMBANKMENT | STRUCTURE EXCAVATION |
|-------------------|----------------------------|----------|------------|-------------------------|
| 10 + 67.37 | 0 | 0 | 0 | 0 |
| 11 + 17.37 | 0 | 0 | 19 | 0 |
| 11 + 50.00 | 0 | 0 | 14 | 0 |
| 11 + 73.85 | 7 | 0 | 12 | 0 |
| 11 + 95.52 | 11 | 0 | 23 | 246 |
| 12 + 17.36 | 5 | 0 | 181 | 340 |
| 12 + 39.20 | 6 | 0 | 173 | 344 |
| 12 + 60.42 | 13 | 0 | 17 | 245 |
| 13 + 00.00 | 12 | 0 | 20 | 0 |
| 13 + 17.35 | 0 | 0 | 5 | 0 |
| 13 + 67.35 | 0 | 0 | 9 | 0 |

NOTE: EMBANKMENT COLUMN DOES NOT INCLUDE BACKFILL FOR UNDERCUT.

NOTE:
APPROXIMATE QUANTITIES ONLY. UNCLASSIFIED EXCAVATION, UNCLASSIFIED STRUCTURE EXCAVATION, BORROW EXCAVATION, FINE GRADING, CLEARING AND GRUBBING AND REMOVAL OF EXISTING PAVEMENT WILL BE PAID FOR AT THE CONTRACT LUMP SUM PRICE FOR "GRADING."

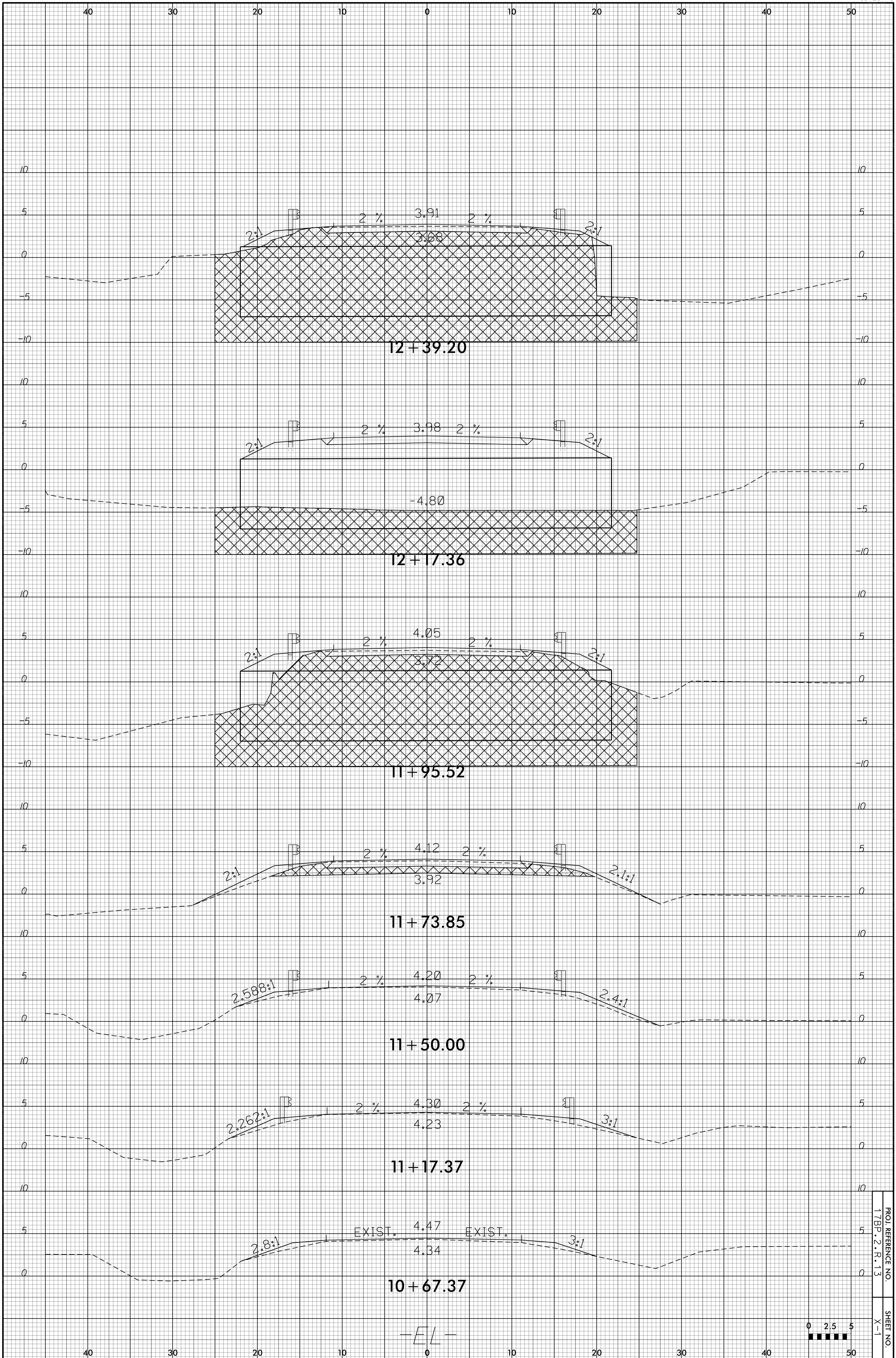

12+39.20

12+17.36

11+95.52

11+73.85

11+50.00

11+17.37

10+67.37

-E/L-

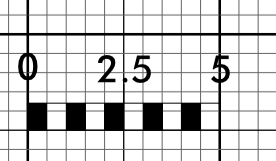

PROJ. REFERENCE NO.
17BP.2.R.13
SHEET NO.
X-1

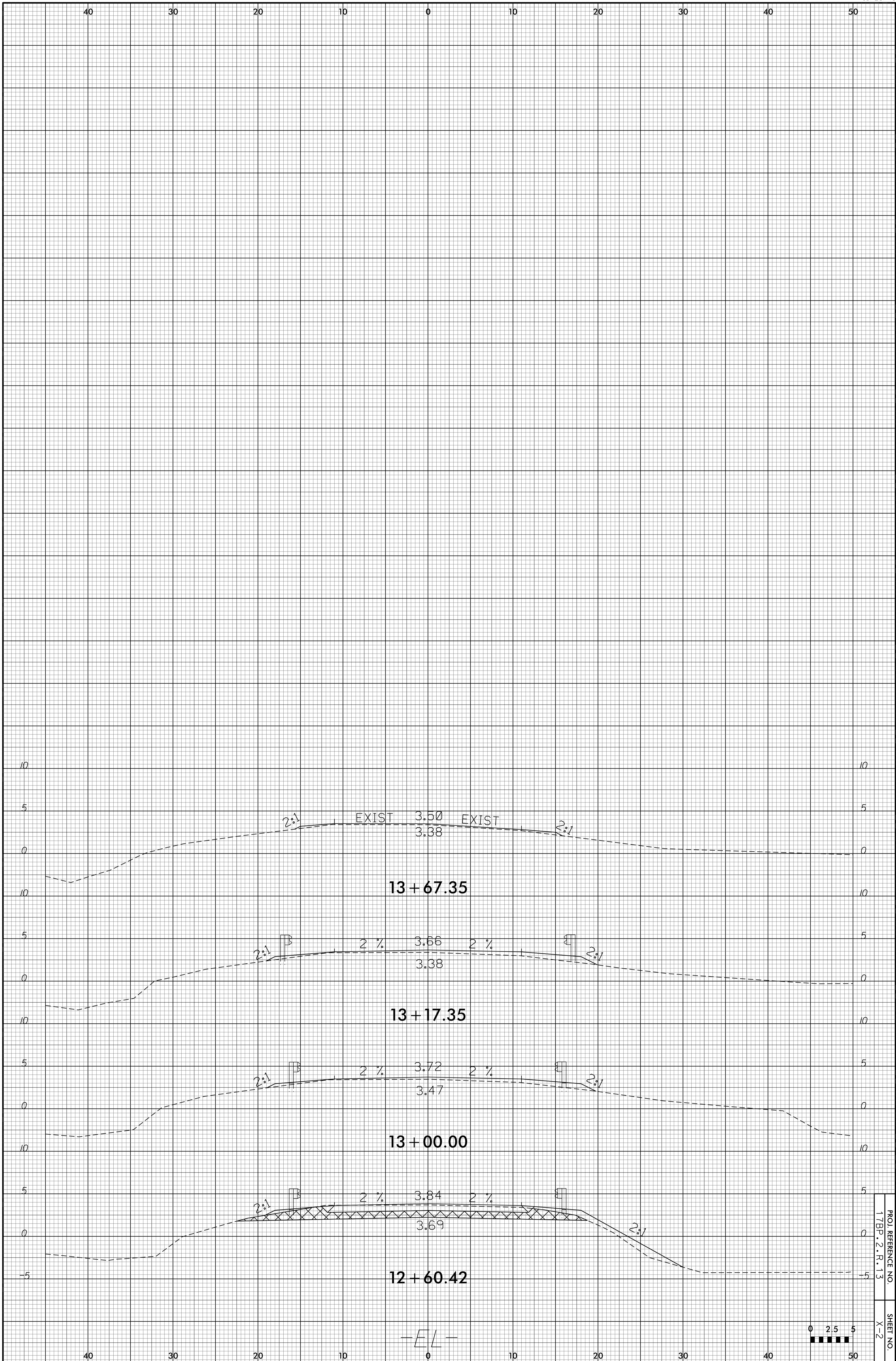

-E/L-

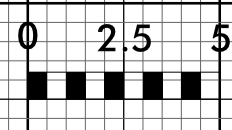

PROJ. REFERENCE NO.
17BP.2.R.13
SHEET NO.
X-2